



PERFORMANCE AND TUNING GUIDE | PUBLIC  
SAP Adaptive Server Enterprise 16.0 SP03  
Document Version: 1.0 – 2019-06-06

# Performance and Tuning Series: Locking and Concurrency Control

# Content

- 1 Introduction to Locking. . . . . 7**
- 1.1 How Locking Affects Performance. . . . . 7
- 1.2 Lock and Data Consistency. . . . . 7
- 1.3 Granularity of Locks and Locking Schemes. . . . . 8
  - Allpages Locking. . . . . 9
  - Datapages Locking. . . . . 10
  - Datarows Locking. . . . . 11
- 1.4 Types of Locks in SAP ASE. . . . . 11
  - Page and Row Locks. . . . . 12
  - Partition Locks. . . . . 13
  - Table Locks. . . . . 15
  - Schema Locks. . . . . 17
  - Demand Locks. . . . . 18
  - Row-locked System Tables. . . . . 20
  - Range Locking for Serializable Reads. . . . . 20
  - Latches. . . . . 21
- 1.5 Lock Compatibility and Lock Sufficiency. . . . . 22
- 1.6 How Isolation Levels Affect Locking. . . . . 25
  - Isolation Level 0, Read Uncommitted. . . . . 26
  - Isolation Level 1, Read Committed. . . . . 27
  - Isolation Level 2, Repeatable Read. . . . . 27
  - Isolation Level 3, Serializable Reads. . . . . 28
  - SAP ASE Default Isolation Level. . . . . 29
- 1.7 Lock Types and Duration During Query Processing. . . . . 29
  - Lock Types During Create Index Commands. . . . . 32
  - Locking for Select Queries at Isolation Level 1. . . . . 32
  - Table Scans and Isolation Levels 2 and 3. . . . . 33
  - When Update Locks Are Not Required. . . . . 33
  - Locking During or Processing. . . . . 34
  - Skip Uncommitted inserts During selects. . . . . 35
  - Using Alternative Predicates to Skip Nonqualifying Rows. . . . . 36
- 1.8 Pseudocolumn-level Locking. . . . . 37
  - Select Queries That Do Not Reference the Updated Column. . . . . 37
  - Qualify Old and New Values for Uncommitted Updates. . . . . 38
- 2 Snapshot Isolation Level and Locking. . . . . 39**

<b>3</b>	<b>Locking Configuration and Tuning.</b>	<b>41</b>
3.1	Locks and Performance.	41
	sp_sysmon and sp_object_stats Usage.	41
	Reduce Lock Contention.	42
	Additional Locking Guidelines.	46
	Improved Concurrency for Partition-Level Online Operations.	46
3.2	Lock Configuration and Promotion Thresholds.	47
	Lock Promotion.	47
	Configuring the SAP ASE Lock Limit.	48
	Set Lock Promotion Thresholds.	50
3.3	Choosing the Locking Scheme for a Table.	55
	Analyzing Existing Applications.	56
	Choosing a Locking Scheme Based on Contention Statistics.	56
	Monitoring and Managing Tables After Conversion.	58
	Applications Not Likely to Benefit from Data-only Locking.	58
3.4	Optimistic Index Locking.	59
	Using Optimistic Index Locking.	60
	Cautions and Issues.	60
<b>4</b>	<b>Lock Tools.</b>	<b>61</b>
4.1	Information About Blocked Processes.	61
4.2	View Locks with sp_lock.	62
4.3	View Locks with sp_familylock.	64
4.4	Intrafamily Blocking During Network Buffer Merges.	65
4.5	Monitor Lock Timeouts.	66
<b>5</b>	<b>Deadlocks and Concurrency.</b>	<b>67</b>
5.1	Server-side Versus Application-side Deadlocks.	67
	Application Deadlock Example.	67
5.2	Server Task Deadlocks.	68
5.3	Deadlocks and Parallel Queries.	68
5.4	Print Deadlock Information to the Error Log.	70
5.5	Deadlock Avoidance.	71
	Lock Acquisition on Objects in the Same Order.	71
	Delay Deadlock Checking.	71
5.6	Identify Tables Where Concurrency is a Problem.	72
5.7	Lock Management Reporting.	73
<b>6</b>	<b>Lock Commands.</b>	<b>74</b>
6.1	Specify the Locking Scheme for a Table.	74
	Specify a Server-Wide Locking Scheme.	74
	Specify a Locking Scheme with Create Table.	75

	Changing a Locking Scheme with alter table. . . . .	75
	Before and After Changing Locking Schemes. . . . .	76
	Expense of Switching To or From Allpages Locking. . . . .	77
	Sort Performance During alter table. . . . .	77
	Specify a Locking Scheme with select into. . . . .	77
6.2	Control Isolation Levels. . . . .	78
	Set Isolation Levels for a Session. . . . .	78
	Syntax for Query-level and Table-level Locking Options. . . . .	79
	holdlock, noholdlock, or shared Usage. . . . .	79
	at isolation Clause Usage. . . . .	80
	Making Locks More Restrictive. . . . .	81
	Making Locks Less Restrictive. . . . .	82
6.3	Readpast Locking. . . . .	82
6.4	Cursors and Locking. . . . .	83
	shared Keyword Usage. . . . .	84
6.5	lock table. . . . .	84
6.6	Lock Timeouts. . . . .	85
6.7	Preventing Blocking Row Counts. . . . .	85
<b>7</b>	<b>Indexes. . . . .</b>	<b>87</b>
7.1	Types of Indexes. . . . .	87
	Index Pages. . . . .	88
	Index Size. . . . .	89
	Using Latch-Free Indexes. . . . .	90
	Hash-Cache BTree Indexes. . . . .	91
7.2	Indexes and Partitions. . . . .	98
	Local Indexes on Partitioned Tables. . . . .	98
	Global Indexes on Partitioned Tables. . . . .	98
	Local versus Global Indexes. . . . .	98
	Unsupported Partition Index Types. . . . .	99
7.3	Creating Partial Indexes. . . . .	99
7.4	Clustered Indexes on Allpages-locked Tables. . . . .	100
	Clustered Indexes and select Operations. . . . .	100
	Clustered Indexes and insert Operations. . . . .	101
	Page Splitting on Full Data Pages. . . . .	102
	Page Splitting on Index Pages. . . . .	104
	Performance Impacts of Page Splitting. . . . .	104
	Overflow Pages. . . . .	104
	Clustered Indexes and delete Operations. . . . .	105
7.5	Nonclustered Indexes. . . . .	107
	Leaf Pages Revisited. . . . .	108
	Nonclustered Index Structure. . . . .	108

	Nonclustered Indexes and select Operations. . . . .	109
	Nonclustered Indexes and insert Operations. . . . .	110
	Nonclustered Indexes and delete Operations. . . . .	111
	Clustered Indexes on Data-only-locked Tables. . . . .	112
7.6	Index Covering. . . . .	112
	Covering Matching Index Scans . . . . .	113
	Covering Nonmatching Index Scans. . . . .	114
7.7	Indexes and Caching. . . . .	115
	Using Separate Caches for Data and Index Pages. . . . .	115
	Index Trips Through the Cache. . . . .	115
<b>8</b>	<b>Indexing for Concurrency Control. . . . .</b>	<b>116</b>
8.1	Indexes and Performance. . . . .	116
8.2	Detecting Indexing Problems. . . . .	117
	Symptoms of Poor Indexing. . . . .	117
8.3	Fixing Corrupted Indexes. . . . .	120
	Repairing a Nonclustered Index on sysobjects. . . . .	121
8.4	Index Limits and Requirements. . . . .	122
8.5	Index Choices. . . . .	123
	Index Keys and Logical Keys. . . . .	124
	Guidelines for Clustered Indexes. . . . .	124
	Clustered Index Selection. . . . .	125
	Candidates for Nonclustered Indexes. . . . .	125
	Function-based Indexes Selection. . . . .	125
	Index Selection. . . . .	126
	Other Indexing Guidelines. . . . .	128
	Nonclustered Indexes Selection. . . . .	128
	Composite Indexes Selection . . . . .	129
	Key Order and Performance in Composite Indexes. . . . .	129
	Advantages and Disadvantages of Composite Indexes. . . . .	131
	online reorg rebuild for Data-only-locked Indexes. . . . .	131
8.6	Techniques for Choosing Indexes. . . . .	131
	Index Choice for a Range Query. . . . .	132
	Add a Point Query with Different Indexing Requirements. . . . .	132
8.7	Index and Statistics Maintenance. . . . .	134
	Drop Indexes That Hurt Performance. . . . .	134
	Choose Space Management Properties for Indexes. . . . .	134
8.8	Additional Indexing Tips. . . . .	134
	Create Artificial Columns. . . . .	135
	Keep Index Entries Short and Avoid Overhead. . . . .	135
	Drop and Rebuild Indexes. . . . .	135
	Configure Enough Sort Buffers. . . . .	136

	Create the Clustered Index First. . . . .	136
	Configure Large Buffer Pools. . . . .	136
8.9	Asynchronous Log Service. . . . .	136
	Understanding the User Log Cache (ULC) Architecture. . . . .	137
	When to Use ALS. . . . .	138
	ALS Usage. . . . .	139

# 1 Introduction to Locking

Configuring locks in SAP ASE includes understanding locking and data consistency, the granularity of locks, types of locks, lock compatibility, and how isolation levels affect locking.

## 1.1 How Locking Affects Performance

SAP Adaptive Server Enterprise (SAP ASE) protects the tables, data pages, or data rows used by active transactions by locking them.

Locking is a concurrency control mechanism: it ensures the consistency of data within and across transactions. Locking is necessary in a multiuser environment, since several users may be working with the same data at the same time.

Locking affects performance when one process holds locks that prevent another process from accessing needed data. This is called lock contention. The process that is blocked by the lock sleeps until the lock is released.

A more serious impact on performance arises from deadlocks. A deadlock occurs when two user processes each have a lock on a page, row, or table and each process wants to acquire a lock on the page, row, or table held by the other. The transaction with the least accumulated CPU time is killed and all of its work is rolled back.

Understanding the types of locks in SAP ASE can help to reduce lock contention and avoid or minimize deadlocks.

## 1.2 Lock and Data Consistency

Data consistency means that if multiple users repeatedly execute a series of transactions, the results are correct for each transaction, each time. Simultaneous retrievals and modifications of data do not interfere with each other: the results of queries are consistent.

In this table example, transactions T1 and T2 are attempting to access data at approximately the same time. T1 is updating values in a column, while T2 needs to report the sum of the values.

Table 1: Consistency Levels in Transactions

T1	Event Sequence	T2
<pre>begin transaction update account set balance = balance - 100 where acct_number = 25 update account set balance = balance + 100 where acct_number = 45 commit transaction</pre>	<p>T1 and T2 start. T1 updates balance for one account by subtracting \$100. T2 queries the sum balance, which is off by \$100 at this point in time—should it return results now, or wait until T1 ends? T1 updates balance of the other account by adding the \$100. T1 ends.</p>	<pre>begin transaction select sum(balance) from account where acct_number &lt; 50 commit transaction</pre>

If T2 runs before T1 starts or after T1 completes, either execution of T2 returns the correct value. But if T2 runs in the middle of transaction T1 (after the first `update`), the result for transaction T2 is different by \$100. While such behavior may be acceptable in some situations, most database transactions must return correct, consistent results.

By default, SAP ASE locks the data used in T1 until the transaction is finished. Only then does it allow T2 to complete its query. T2 “sleeps,” or pauses in execution, until the lock it needs is released when T1 is completed.

The alternative, returning data from uncommitted transactions, is known as a dirty read. If results do not need to be exact, T2 can read the uncommitted changes from T1 and return results immediately, without waiting for the lock to be released.

Locking is handled automatically by SAP ASE, with options that can be set at the session and query level by the user. You should know how and when to use transactions to preserve data consistency while maintaining high performance and throughput.

## 1.3 Granularity of Locks and Locking Schemes

The granularity of locks in a database refers to how much of the data is locked at one time.

In theory, a database server can lock as much as an entire database or as little as one column of data. Such extremes affect the concurrency (number of users that can access the data) and locking overhead (amount of work to process lock requests) in the server. SAP ASE supports locking at the table, partition, page, and row level.

By locking at higher levels of granularity, the amount of work required to obtain and manage locks is reduced. If a query needs to read or update many rows in a table it can acquire:

- A table-level lock
- A lock for each page that contains a required row
- A partition-level lock
- A lock on each row



Less overall work is required when a table-level lock is used, but large-scale locks can degrade performance by making other users wait until locks are released. Decreasing lock granularity makes more data accessible to other users. Finer granularity locks can degrade performance, since more work is necessary to maintain and coordinate the increased number of locks. To achieve optimum performance, a locking scheme must balance the needs of concurrency and overhead.

SAP ASE provides these locking schemes:

- Allpages locking, which locks data pages and index pages
- Datapages locking, which locks only data pages
- Datarows locking, which locks only data rows

For each locking scheme, SAP ASE can lock an entire table or partition, for queries that acquire many page or row locks, or can lock only the affected pages or rows.

### i Note

The terms “data-only-locking” and “data-only-locked table” refer to both the datapages and datarows locking schemes, and are typically referred to as “DOL” tables. Allpages-locked tables are known as “APL” tables.

## 1.3.1 Allpages Locking

Allpages locking locks data pages and index pages.

When a query updates a value in a row in an allpages-locked table, the data page is locked with an exclusive lock. Any index pages affected by the update are also locked with exclusive locks. These locks are transactional, meaning that they are held until the end of the transaction.

### Locks Held During Allpages Locking

```
insert authors values("Mark", "Twain")
```

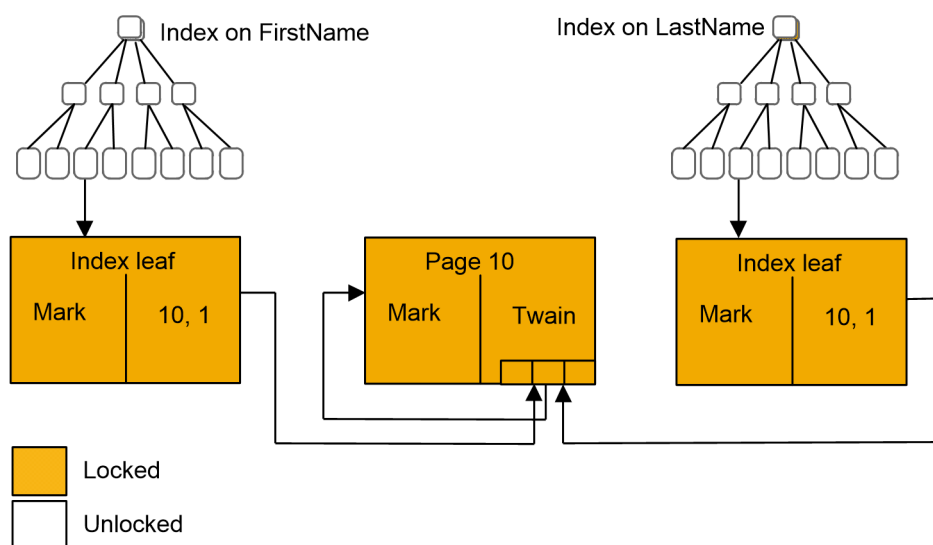

In many cases, concurrency problems that result from allpages locking arise from the index page locks, rather than the locks on the data pages themselves. Data pages have longer rows than indexes, and often have a small number of rows per page. If index keys are short, an index page can store between 100 and 200 keys. An exclusive lock on an index page can block other users who need to access any of the rows referenced by the index page, a far greater number of rows than on a locked data page.

## 1.3.2 Datapages Locking

In datapages locking, entire data pages are still locked, but index pages are not locked.

When a row needs to be changed on a data page, that page is locked, and the lock is held until the end of the transaction. The updates to the index pages are performed using latches, which are nontransactional. Latches are held only as long as required to perform the physical changes to the page and are then released immediately. Index page entries are implicitly locked by locking the data page. No transactional locks are held on index pages.

### Locks Held During Datapages Locking

```
insert authors values("Mark", "Twain")
```

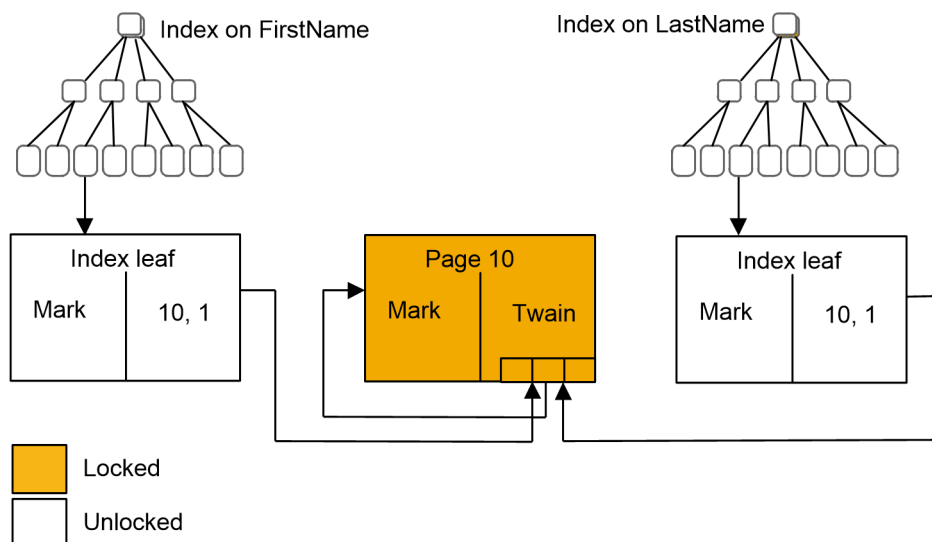

### Related Information

[Latches \[page 21\]](#)

### 1.3.3 Datarows Locking

In datarows locking, row-level locks are acquired on individual rows on data pages. Index rows and pages are not locked.

When a row is changed on a data page, a nontransactional latch is acquired on the page. The latch is held while the physical change is made to the data page, then the latch is released. The lock on the data row is held until the end of the transaction. The index rows are updated, using latches on the index page, but are not locked. Index entries are implicitly locked by acquiring a lock on the data row.

#### Locks Held During Datarows Locking

```
insert authors values("Mark", "Twain")
```

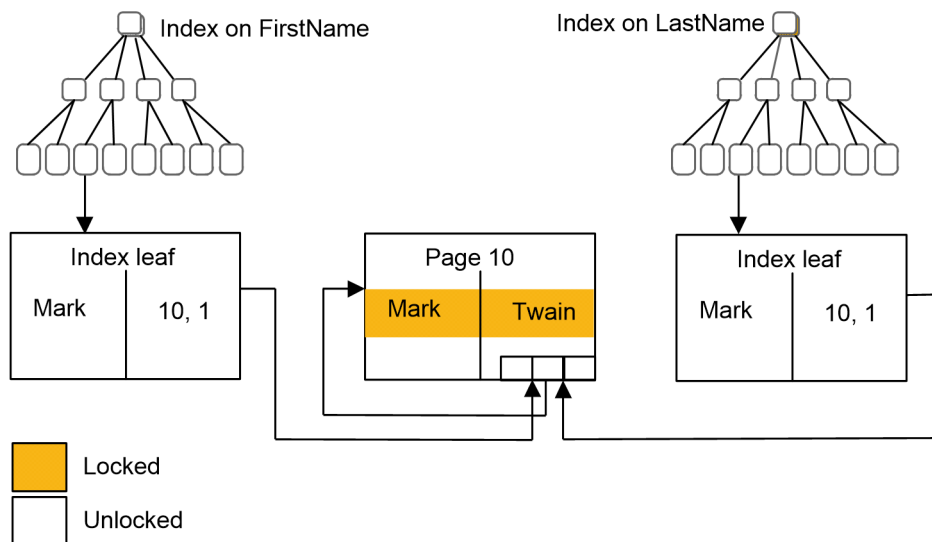

## 1.4 Types of Locks in SAP ASE

SAP ASE has three levels of locking.

- Page locks or partition locks (for partition-lock enabled tables) or table locks are used for tables that use allpages locking or datapages locking.
- Row locks, partition locks (for partition-lock enabled tables), or table locks are used for tables that use datarows locking.

Page or row locks are less restrictive (or smaller) than partition or table locks. A page lock locks all the rows on a data page or an index page; a table lock locks an entire table; a partition lock locks an entire partition (applicable only for data partitions). A row lock locks only a single row on a page. SAP ASE uses page or row locks whenever possible to reduce contention and to improve concurrency.

SAP ASE uses a partition or table lock to provide more efficient locking when an entire partition or table or a large number of pages or rows is accessed by a statement. Locking strategy is directly tied to the query plan, so a query plan can be as important for its locking strategies as for its I/O implications. For data-only-locked tables, an `update` or `delete` statement without a useful index performs a table scan and acquires a table lock. For example, the following statement acquires a table lock if the `account` table uses the `datarows` or `datapages` locking scheme:

```
update account set balance = balance * 1.05
```

An `update` or `delete` statement using an index begins by acquiring page or row locks. It acquires a partition or table lock only when a large number of pages or rows are affected. To avoid the overhead of managing hundreds of locks on a table or partition, SAP ASE uses a lock promotion threshold setting (configured with `sp_setpglockpromote`, `sp_setpglockpromote_ptn`, `sp_setrowlockpromote`, `sp_setrowlockpromote_ptn`). Once table scan accumulates more page or row locks than allowed by the lock promotion threshold, SAP ASE tries to issue a partition or table lock, depending on corresponding lock promotion thresholds. If it succeeds, the page or row locks are no longer necessary and are released.

SAP ASE chooses which type of lock to use after it determines the query plan. The way a query or transaction is written can affect the type of lock the server chooses. You can force the server to make certain locks more or less restrictive by specifying options for `select` queries or by changing the transaction's isolation level. Applications can use the `lock table` command to explicitly request a table lock.

## Related Information

[Lock Configuration and Promotion Thresholds \[page 47\]](#)

[Control Isolation Levels \[page 78\]](#)

### 1.4.1 Page and Row Locks

SAP ASE has many types of page and row locks.

- Shared locks – SAP ASE applies shared locks for read operations. If a shared lock has been applied to a data page or data row or to an index page, other transactions can also acquire a shared lock, even when the first transaction is active. However, no transaction can acquire an exclusive lock on the page or row until all shared locks on the page or row are released. This means that many transactions can simultaneously read a page or row, but no transaction can change data on the page or row while a shared lock exists. Transactions that require an exclusive lock wait for, or “block,” for the release of the shared locks before continuing.  
By default, SAP ASE releases shared locks after it finishes scanning the page or row. It does not hold shared locks until the statement is completed or until the end of the transaction unless requested to do so by the user.

- Exclusive locks – SAP ASE applies an exclusive lock for a data modification operation. When a transaction has an exclusive lock, other transactions cannot acquire a lock of any kind on the page or row until the exclusive lock is released at the end of its transaction. The other transactions wait or “block” until the exclusive lock is released.
- Update locks – SAP ASE applies an update lock during the initial phase of an `update`, `delete`, or `fetch` (for cursors declared `for update`) operation while the page or row is being read. The update lock allows shared locks on the page or row, but does not allow other update or exclusive locks. Update locks help avoid deadlocks and lock contention. If the page or row needs to be changed, the update lock is promoted to an exclusive lock as soon as no other shared locks exist on the page or row.

In general, read operations acquire shared locks, and write operations acquire exclusive locks. For operations that delete or update data, SAP ASE applies page-level or row-level exclusive and update locks only if the column used in the search argument is part of an index. If no index exists on any of the search arguments, SAP ASE must acquire a table-level lock.

This example table shows what kind of page or row locks SAP ASE uses for basic SQL statements. For these examples, there is an index `acct_number`, but no index on `balance`.

Statement	Allpages-Locked Table	Datarows-Locked Table
<pre>select balance from account where acct_number = 25</pre>	Shared page lock	Shared row lock
<pre>insert account values (34, 500)</pre>	Exclusive page lock on data page and exclusive page lock on leaf-level index page	Exclusive row lock
<pre>delete account where acct_number = 25</pre>	Update page locks followed by exclusive page locks on data pages and exclusive page locks on leaf-level index pages	Update row locks followed by exclusive row locks on each affected row
<pre>update account set balance = 0 where acct_number = 25</pre>	Update page lock on data page and exclusive page lock on data page	Update row locks followed by exclusive row locks on each affected row

## Related Information

[Locking for Select Queries at Isolation Level 1 \[page 32\]](#)

### 1.4.2 Partition Locks

Partition locks are an attribute of a partitioned table and are applicable to all types of partitioning.

- Intent partition lock – indicates that page-level or row-level locks are held on a partition of table. SAP ASE applies an intent partition lock with each page or row lock, so an intent lock can be either an exclusive lock

or a shared lock. Setting an intent partition lock prevents other transactions from acquiring conflicting partition-level locks on the partition of a table as the partition locks are in effect for the transaction.

- Shared partition lock – similar to a shared page or row lock, except that it affects the entire partition.
- Exclusive partition lock – similar to an exclusive page or row lock, except that it affects the entire partition.
- Covering partition lock – these locks are acquired on unknown partition IDs, so one table partition is locked in SH\_PTIN or EX\_PTIN mode.

This example table shows the respective partition locks of page or row locks SAP ASE uses for basic SQL statements. For these examples, there is an index on `acct_number`.

Statement	Allpages-Locked Table	Datarows-Locked Table
<code>select balance from account where acct_number = 25</code>	Intent shared partition lock Shared page lock	Intent shared partition lock Shared row lock
<code>insert account values (34, 500)</code>	Intent exclusive partition lock Exclusive page lock on data page Exclusive page lock on leaf index pages	Intent exclusive partition lock Exclusive row lock
<code>delete account where acct_number = 25</code>	Intent exclusive partition lock Update page locks followed by exclusive page locks on data pages and leaf-level index pages	Intent exclusive partition lock Update row locks followed by exclusive row locks on data rows
<code>update account set balance = 0 where acct_number = 25</code>	Intent exclusive partition lock Update page locks followed by exclusive page locks on data pages and leaf-level index pages	Intent exclusive partition lock Update row locks followed by exclusive row locks on data rows.

## 1.4.2.1 Partition Lock Name

SAP ASE uniquely identifies the partition lock with a combination of database ID (<dbid>), object ID (<objid>), and partition ID (<ptnid>).

### Unknown Partition ID

If the partition ID is unknown, the server acquires locks on the unknown partition ID, which has the value -1. Locks on the unknown partition ID prevent SH\_PTIN or EX\_PTIN lock requests (using a covering partition lock) in any table partition of the table.

## 1.4.2.2 Enabling Partition Locking

Use `sp_chgattribute` to enable or disable partition-level locking. By default, partition locking is disabled.

### Context

Partition-level locking can be enabled only on user tables with more than one data partition. Partition-level locking can not be enabled for system tables and temporary tables.

The syntax is:

```
sp_chgattribute <objectname>, 'ptn_locking', value
```

Parameters:

`<objectname>` – is the name of the table on which to change `ptn_locking`.

`value` – set to 1 to enable and 0 to disable partition-level locking.

Permissions:

Only the object owner can execute `sp_chgattribute`.

#### ❖ Example

##### Examples

This example enables partition-level locking for the *authors* table:

```
sp_chgattribute authors, "ptn_locking", 1
```

This example disables partition-level locking for the *authors* table:

```
sp_chgattribute authors, "ptn_locking", 0
```

## 1.4.3 Table Locks

SAP ASE has many types of table locks.

- Intent lock – indicates that page-level or row-level locks are held on a table. SAP ASE applies an intent table lock with each shared or exclusive page or row lock, so an intent lock can be either an exclusive lock or a shared lock. Setting an intent lock prevents other transactions from acquiring conflicting table-level locks on the table containing the locked page. An intent lock is held as long as page or row locks are in effect for the transaction.
- Shared lock – similar to a shared page or row lock, except that it affects the entire table. For example, SAP ASE applies a shared table lock for a `select` command with a `holdlock` clause if the command does not use an index. A `create nonclustered index` command also acquires a shared table lock.
- Exclusive lock – similar to an exclusive page or row lock, except that it affects the entire table. For example, SAP ASE applies an exclusive table lock during a `create clustered index` command. `update` and

`delete` statements on data-only-locked tables require exclusive table locks if their search arguments do not reference indexed columns of the object.

This example table shows the respective page, row, and table locks of page or row locks SAP ASE uses for basic SQL statements. For these examples, there is an index on `acct_number`.

Statement	Allpages-Locked Table	Datarows-Locked Table
<pre>select balance from account where acct_number = 25</pre>	Intent shared table lock Shared page lock	Intent shared table lock Shared row lock
<pre>insert account values (34, 500)</pre>	Intent exclusive table lock Exclusive page lock on data page Exclusive page lock on leaf index pages	Intent exclusive table lock Exclusive row lock
<pre>delete account where acct_number = 25</pre>	Intent exclusive table lock Update page locks followed by exclusive page locks on data pages and leaf-level index pages	Intent exclusive table lock Update row locks followed by exclusive row locks on data rows
<pre>update account set balance = 0 where acct_number = 25</pre>	Intent exclusive table lock Update page locks followed by exclusive page locks on data pages and leaf-level index pages	With an index on <code>acct_number</code> , intent exclusive table lock Update row locks followed by exclusive row locks on data rows. With no index on a data-only-locked table, exclusive table lock

Exclusive table locks are also applied to tables during `select into` operations, including temporary tables created with `tempdb..tablename` syntax. Tables created with `#tablename` are restricted to the sole use of the process that created them, and are not locked.

### 1.4.3.1 Commands that Take Intent Locks

Versions of SAP ASE earlier than 15.0.2 used table locks to archive system catalog synchronization. SAP ASE version 15.0.2 and later uses intent locks for table-level synchronization and row locks for row-level synchronization.

Earlier releases of SAP ASE locked the entire system catalog while performing operations on the object, so a single lock request was made. However, SAP ASE version 15.0.2 and later requests locks for all applicable rows while performing operations on the object if there are multiple rows corresponding to an object in a system catalog.

This change means that SAP ASE version 15.0.2 and later requests more locks to perform the same operation than earlier releases, and increases the number of lock resources the system needs. Consequently, you may need to change the `number of locks` configuration option after you upgrade SAP ASE.

These commands take intent locks in SAP ASE version 15.0.2 later when they update a system table:

- `create table`
- `drop table`



- create index
- drop index
- create view
- drop view
- create procedure
- drop procedure
- create trigger
- drop trigger
- create default
- drop default
- create rule
- drop rule
- create function
- drop function
- create functional index
- drop functional index
- create computed column
- drop computed column
- select into
- alter table (all versions)
- create schema
- reorg rebuild

If two or more of these commands simultaneously access or update the same system table, their intent locks do not conflict with each other so they do not block on the system table.

The `sp_fixindex` and `sp_spaceusage` system procedures provide information about the row-locked catalogs.

## 1.4.4 Schema Locks

Schema locks allow enhanced partition-level operations to update table schema or metadata by achieving isolation from concurrent operations.

The schema locks are:

- Shared schema lock – indicates that a task is using the current schema of the table for query execution. Scans and DMLs acquire this lock before starting the execution of the query.
- Exclusive schema lock – indicates that a task is changing the schema of the table. The partition-level operation acquires this lock to update the schema of the table.

## 1.4.5 Demand Locks

SAP ASE sets a demand lock to indicate that a transaction is next in the queue to lock a table, page, or row.

Since many readers can hold shared locks on a given page, row, partition, or table, tasks that require exclusive locks are queued after a task that already holds a shared lock. SAP ASE allows up to three readers' tasks to skip ahead of a queued update task.

After a write transaction has been skipped by three tasks or families (in the case of queries running in parallel) that acquire shared locks, SAP ASE gives a demand lock to the write transaction. Any subsequent requests for shared locks are queued behind the demand lock.

As soon as the readers queued ahead of the demand lock release their locks, the write transaction acquires its lock and can proceed. The read transactions queued behind the demand lock wait for the write transaction to finish and release its exclusive lock.

SAP ASE uses demand locks to avoid lock starvation for write transactions (when the required number of locks are not available).

### 1.4.5.1 Demand Locking with Serial Execution

An example of how the demand lock scheme works for serial query execution.

This illustration shows four tasks with shared locks in the active lock position, meaning that all four tasks are currently reading the page. These tasks can access the same page simultaneously because they hold compatible locks. Two other tasks are in the queue waiting for locks on the page.

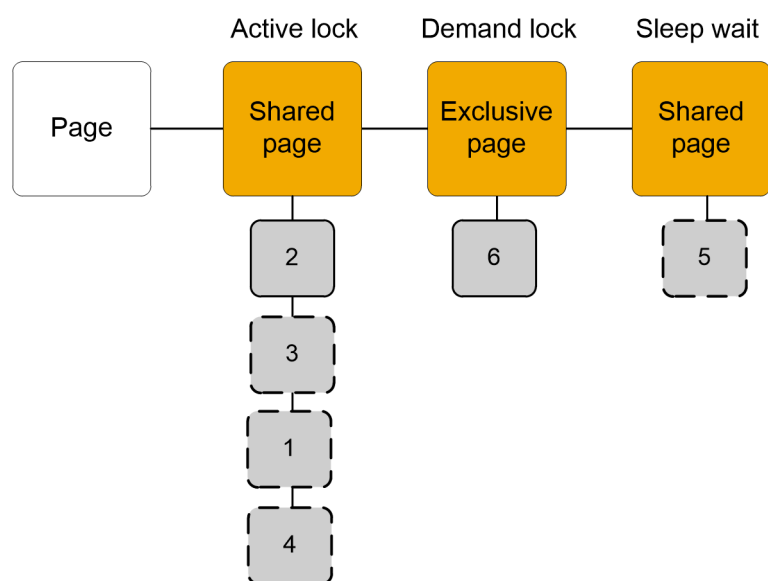

Here is a series of events that could lead to the situation shown:

- Originally, task 2 holds a shared lock on the page.

- Task 6 makes an exclusive lock request, but must wait until the shared lock is released because shared and exclusive locks are not compatible.
- Task 3 makes a shared lock request, which is immediately granted because all shared locks are compatible.
- Tasks 1 and 4 make shared lock requests, which are also immediately granted for the same reason.
- Task 6 has now been skipped three times, and is granted a demand lock.
- Task 5 makes a shared lock request. It is queued behind task 6's exclusive lock request because task 6 holds a demand lock. Task 5 is the fourth task to make a shared page request.
- After tasks 1, 2, 3, and 4 finish their reads and release their shared locks, task 6 is granted its exclusive lock.
- After task 6 finishes its write and releases its exclusive page lock, task 5 is granted its shared page lock.

## 1.4.5.2 Demand Locking with Parallel Execution

An example of how the demand lock scheme works for parallel query execution.

When queries run in parallel, demand locking treats all shared locks from a family of worker processes as though they were a single task. The demand lock permits reads from three families (or a total of three serial tasks and families combined) before granting the exclusive lock.

This illustration shows how the demand lock scheme works when parallel query execution is enabled. The figure shows six worker processes from three families with shared locks. A task waits for an exclusive lock, and a worker process from a fourth family waits behind the task.

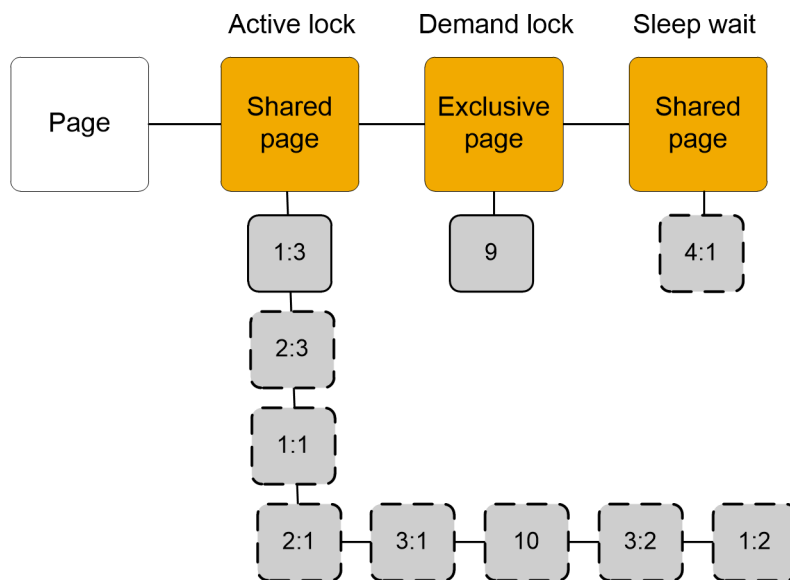

Here is a series of events that could lead to the situation shown:

- Originally, worker process 1:3 (worker process 3 from a family with family ID 1) holds a shared lock on the page.
- Task 9 makes an exclusive lock request, but must wait until the shared lock is released.
- Worker process 2:3 requests a shared lock, which is immediately granted because shared locks are compatible. The skip count for task 9 is now 1.

- Worker processes 1:1, 2:1, 3:1, task 10, and worker processes 3:2 and 1:2 are consecutively granted shared lock requests. Since family ID 3 and task 10 have no prior locks queued, the skip count for task 9 is now 3, and task 9 is granted a demand lock.
- Finally, worker process 4:1 makes a shared lock request, but it is queued behind task 9's exclusive lock request.
- Any additional shared lock requests from family IDs 1, 2, and 3 and from task 10 are queued ahead of task 9, but all requests from other tasks are queued after it.
- After all the tasks in the active lock position release their shared locks, task 9 is granted its exclusive lock.
- After task 9 releases its exclusive page lock, task 4:1 is granted its shared page lock.

## 1.4.6 Row-locked System Tables

System tables—except message tables, fake tables (nonrow-oriented tables), and logs—in SAP ASE version 15.0 and later are row-locked.

These tables no longer have a clustered index, but instead have a “placement” index, with a new index ID. Pages at the data level for SAP ASE are not chained together, and table starting locations are no longer set, but are randomly generated.

## 1.4.7 Range Locking for Serializable Reads

Rows that can appear or disappear from a results set are called phantoms. Some queries that require phantom protection (queries at isolation level 3) use range locks.

Isolation level 3 requires serializable reads within the transaction. A query at isolation level 3 that performs two read operations with the same query clauses should return the same set of results each time. No other task can modify:

- One of the result rows so that it no longer qualifies for the serializable read transaction, by updating or deleting the row
- A row that is not included in the serializable read result set so that the row now qualifies, or insert a row that would qualify for the result set

SAP ASE uses range locks, infinity key locks, and next-key locks to protect against phantoms on data-only-locked tables. Allpages-locked tables protect against phantoms by holding locks on the index pages for the serializable read transaction.

When a query at isolation level 3 (serializable read) performs a range scan using an index, all the keys that satisfy the query clause are locked for the duration of the transaction. Also, the key that immediately follows the range is locked, to prevent new values from being added at the end of the range. If there is no next value in the table, an infinity key lock is used as the next key, to ensure that no rows are added after the last key in the table.

Range locks can be shared, update, or exclusive locks; depending on the locking scheme, they are either row locks or page locks. `sp_lock` output shows “Fam dur, Range” in the `context` column for range locks. For infinity key locks, `sp_lock` shows a lock on a nonexistent row, row 0 of the root index page and “Fam dur, Inf key” in the `context` column.

Every transaction that performs an insert or update to a data-only-locked table checks for range locks.

## Related Information

[How Isolation Levels Affect Locking \[page 25\]](#)

### 1.4.8 Latches

Latches are nontransactional synchronization mechanisms used to guarantee the physical consistency of a page. While rows are being inserted, updated, or deleted, only one SAP ASE process can access the page. Latches are used for datapages and datarows locking, but not for allpages locking.

The most important distinction between a lock and a latch is duration:

- A lock can persist for a long period of time: while a page is being scanned, while a disk read or network write takes place, for the duration of a statement, or for the duration of a transaction.
- A latch is held only for the length of time required to insert or move a few bytes on a data page, to copy pointers, columns, or rows, or to acquire a latch on another index page.

Use the `LFB memory size` configuration parameter to determine the size of the Latch-Free B-tree (LFB) bucket pool. By default, the LFB bucket pool uses the delta update for all index pages. However, you can configure the `LFB memory size` configuration parameter so that the LFB bucket pool uses only delta updates for non-leaf pages. See the *Reference Manual: Configuration Parameters*. For example, if you enable `LFB memory size`:

```
sp_configure 'LFB memory size', 10000
```

And set this database option for the `pubs2` database on the `titlesind` index:

```
sp_chgattribute 'titles.titleind', 'optimistic_LFB', 1
```

The `titlesind` index uses only delta updates for non-leaf pages

#### 1.4.8.1 Metadata and Latch Management Enhancements

SAP ASE Enterprise version 16.0 and later decreases CPU utilization for latch conflicts in environments that have very high transaction rates.

Including, decreased contention:

- On internal structures during very high transaction rate cross-database queries and transactions, including contention on locks, latches, and data caches due to implicit or explicit cross-database references
- During high transaction-rate operations on tables with a large number of partitions
- On internal structures during very high rates of create and drop table, including decreased lock and latch contention on some system tables

These features are intended to enhance performance: you should not notice any performance degradation when SAP ASE uses these enhancements. The metadata and latch management enhancements are enabled by default, and you need not to perform any configuration to enable these enhancements.

SAP ASE version 16.0 and later decreases CPU utilization during latch conflicts in very high transaction rate environments.

## 1.5 Lock Compatibility and Lock Sufficiency

Lock compatibility and lock sufficiency are two basic concepts that support issues of locking and concurrency.

- Lock compatibility – if a task holds a lock on any resource (for example, row, page, partition, or table) can another task also hold a lock on the same resource?
- Lock sufficiency, for the current task – is the current lock held on any resource (for example, row, page, partition, or table) sufficient if the task needs to access the resource again?

Lock compatibility affects performance when users must acquire a lock on a row or page, and that row or page is already locked by another user with an incompatible lock. The task that needs the lock waits, or blocks, until the incompatible locks are released.

Lock sufficiency works with lock compatibility. If a lock is sufficient, the task does not need to acquire a different type of lock. For example, if a task updates a row in a transaction, it holds an exclusive lock. If the task then selects from the row before committing the transaction, the exclusive lock on the row is sufficient; the task does not need to make an additional lock request. The opposite case is not true: if a task holds a shared lock on a page or row, and wants to update the row, the task may need to wait to acquire its exclusive lock if other tasks also hold shared locks on the page.

Can Another Process Immediately Acquire:

If One Process Has:	Can Another Process Immediately Acquire:					
	A Shared Table Lock?	A Shared Page or Row Lock, or an Update Page or Row Lock?	An Exclusive Table Lock?	An Exclusive Row or Page Lock?	A Shared Table Intent Lock?	An Exclusive Table Intent Lock?
A shared table lock	Yes	Yes	No	No	Yes	No
A shared page or row lock, or an update page or row lock (shared read lock before an exclusive lock)	Yes	Yes	No	<ul style="list-style-type: none"> <li>• Yes – if a different row or page</li> <li>• No – if the same row or page</li> </ul>	Yes	Yes
An exclusive table lock	No	No	No	No	No	No

Can Another Process Immediately Acquire:

If One Process Has:	A Shared Table Lock?	A Shared Page or Row Lock, or an Update Page or Row Lock?	An Exclusive Table Lock?	An Exclusive Row or Page Lock?	A Shared Table Intent Lock?	An Exclusive Table Intent Lock?
An exclusive row or page lock	No	<ul style="list-style-type: none"> <li>• Yes – if a different row or page</li> <li>• No – if the same row or page</li> </ul>	No	<ul style="list-style-type: none"> <li>• Yes – if a different row or page</li> <li>• No – if the same row or page</li> </ul>	Yes	Yes
A shared table intent lock (preventing new conflicting exclusive table locks)	Yes	Yes	No	Yes	Yes	Yes
An exclusive intent lock (preventing new conflicting shared or exclusive table locks)	No	Yes	No	Yes	Yes	Yes

This table describes lock sufficiency:

Is That Lock Sufficient if the Task Needs:

If a Task Has:	A Shared Lock	An Update Lock	An Exclusive Lock
A shared lock	Yes	No	No
An update lock	Yes	Yes	No
An exclusive lock	Yes	Yes	Yes

This table summarizes partition lock compatibility:

Can Another Process Acquire:

Lock Type Held:	An Exclusive Partition Lock?	A Shared Partition Lock?	An Exclusive Intent Partition Lock?	A Shared Intent Partition Lock?	An Exclusive Covering Partition Lock?	A Shared Covering Partition Lock?
An exclusive partition lock	No	No	No	No	No	No
A shared partition lock	No	Yes	No	Yes	No	Yes

Can Another Process Acquire:

Lock Type Held:	An Exclusive Partition Lock?	A Shared Partition Lock?	An Exclusive Intent Partition Lock?	A Shared Intent Partition Lock?	An Exclusive Covering Partition Lock?	A Shared Covering Partition Lock?
An exclusive intent partition lock	No	No	Yes	Yes	No	No
A shared intent partition lock	No	Yes	Yes	Yes	No	Yes
An exclusive covering partition lock	No	No	No	No	Yes	Yes
A shared covering partition lock	No	Yes	No	Yes	Yes	Yes

This table describes a sufficiency matrix for partition locks:

Is That Lock Sufficient if the Task Needs:

Lock Type Held:	An Exclusive Partition Lock?	A Shared Partition Lock?	An Exclusive Intent Partition Lock?	A Shared Intent Partition Lock?	An Exclusive Covering Partition Lock?	A Shared Covering Partition Lock?
An exclusive partition lock	Yes	Yes	Yes	Yes	Yes	Yes
A shared partition lock	No	Yes	No	Yes	No	Yes
An exclusive intent partition lock	No	No	Yes	Yes	No	No
A shared intent partition lock	No	No	No	Yes	No	No
An exclusive covering partition lock	No	No	No	No	Yes	Yes
A shared covering partition lock	No	No	No	No	No	Yes

This table describes a sufficiency matrix for schema locks:

Table 2:

Is That Lock Sufficient if the Task Needs:

Lock Type Held:	An Exclusive Schema Lock?	A Shared Schema Lock?
An exclusive schema lock	Yes	Yes



#### Is That Lock Sufficient if the Task Needs:

Lock Type Held:	An Exclusive Schema Lock?	A Shared Schema Lock?
A shared schema lock	No	Yes

This table summarizes partition lock compatibility, showing when locks can be acquired immediately.

#### Can Another Process Acquire:

Lock Type Held:	An Exclusive Schema Lock?	A Shared Schema Lock?
An exclusive schema lock	No	No
A shared schema lock	No	Yes

## 1.6 How Isolation Levels Affect Locking

The SQL standard defines four levels of isolation for SQL transactions.

Each isolation level specifies the kinds of interactions that are not permitted while concurrent transactions are executing—that is, whether transactions are isolated from each other, or if they can read or update information in use by another transaction. Higher isolation levels include the restrictions imposed by the lower levels.

Number	Name	Description
0	<code>read uncommitted</code>	The transaction is allowed to read uncommitted changes to data.
1	<code>read committed</code>	The transaction is allowed to read only committed changes to data.
2	<code>repeatable read</code>	The transaction can repeat the same query, and no rows that have been read by the transaction are updated or deleted.
3	<code>serializable read</code>	The transaction can repeat the same query, and receive exactly the same results. No rows can be inserted that appear in the result set.

You can choose the isolation level for all `select` queries during a session, or you can choose the isolation level for a specific query or table in a transaction.

At all isolation levels, all inserts, updates, and deletes acquire exclusive locks and hold them for the duration of the transaction.

### **i** Note

For tables that use allpages locking, requesting isolation level 2 also enforces isolation level 3. The SAP ASE default isolation level is level 1.

## 1.6.1 Isolation Level 0, Read Uncommitted

Level 0, also known as read uncommitted, allows a task to read uncommitted changes to data in the database. This is also known as a dirty read, since the task can display results that are later rolled back.

T3	Event Sequence	T4
<pre>begin transaction update account set balance = balance - 100 where acct_number = 25 rollback transaction</pre>	T3 and T4 start. T3 updates balance for one account by subtracting \$100. T4 queries current sum of balance for accounts. T4 ends. T3 rolls back, invalidating the results from T4.	<pre>begin transaction select sum(balance) from account where acct_number &lt; 50 commit transaction</pre>

If transaction T4 queries the table after T3 updates it, but before it rolls back the change, the amount calculated by T4 is off by \$100. The `update` statement in T3 acquires an exclusive lock on `account`. However, T4 does not try to acquire a shared lock before querying `account`, so it is not blocked by T3. The opposite is also true. If T4 begins to query `account` at isolation level 0 before T3 starts, T3 can still acquire its exclusive lock on `account` while T4's query executes, because T4 does not hold any locks on the pages it reads.

At isolation level 0, SAP ASE performs dirty reads by:

- Allowing another task to read rows, pages, or tables that have exclusive locks; that is, to read uncommitted changes to data.
- Not applying shared locks on rows, pages, or tables being searched.

If the table uses allpages locking, a unique index is required to perform an isolation level 0 read, unless the database is read-only. The index is required to restart the scan if an update by another process changes the query's result set by modifying the current row or page. Forcing the query to use a table scan or a nonunique index can lead to problems if there is significant update activity on the underlying table, and is not recommended.

Applications that can use dirty reads may see better concurrency and fewer deadlocks than when the same data is accessed at a higher isolation level. If transaction T4 requires only an estimate of the current sum of account balances, which probably changes frequently in a very active table, T4 should query the table using isolation level 0. Other applications that require data consistency, such as queries of deposits and withdrawals to specific accounts in the table, should avoid using isolation level 0.

Isolation level 0 can improve performance for applications by reducing lock contention, but can impose performance costs in two ways:

- Dirty reads make in-cache copies of dirty data that the isolation level 0 application needs to read.
- If a dirty read is active on a row, and the data changes so that the row is moved or deleted, the scan must be restarted, which may incur additional logical and physical I/O.

During deferred update of a data row, there can be a significant time interval between the `delete` of the index row and the `insert` of the new index row. During this interval, there is no index row corresponding to the data row. If a process scans the index during this interval at isolation level 0, it does not return the old or new value of the data row. See "Deferred updates" in Chapter 1, "Understanding Query Processing" in *Performance and Tuning Series: Query Processing and Abstract Plans*.

`sp_sysmon` reports on these factors. See "Data Cache Management" in *Performance and Tuning Series: Monitoring SAP ASE with sp\_sysmon*.

## 1.6.2 Isolation Level 1, Read Committed

Level 1, also known as *read committed*, prevents dirty reads.

Queries at level 1 can read only committed changes to data. At isolation level 1, if a transaction needs to read a row that has been modified by an incomplete transaction in another session, the transaction waits until the first transaction completes (either commits or rolls back.)

T5	Event Sequence	T6
<pre>begin transaction update account set balance = balance - 100 where acct_number = 25 rollback transaction</pre>	<p>T5 and T6 start. T5 updates account after getting exclusive lock. T6 tries to get shared lock to query account but must wait until T5 releases its lock. T5 ends and releases its exclusive lock. T6 gets shared lock, queries account, and ends.</p>	<pre>begin transaction select sum(balance) from account where acct_number &lt; 50 commit transaction</pre>

When the `update` statement in transaction T5 executes, SAP ASE applies an exclusive lock (a row-level or page-level lock if `acct_number` is indexed; otherwise, a table-level lock) on `account`.

If T5 holds an exclusive table lock, T6 blocks trying to acquire its shared intent table lock. If T5 holds exclusive page or exclusive row locks, T6 can begin executing, but is blocked when it tries to acquire a shared lock on a page or row locked by T5. The query in T6 cannot execute (preventing the dirty read) until the exclusive lock is released, when T5 ends with the `rollback`.

While the query in T6 holds its shared lock, other processes that need shared locks can access the same data, and an update lock can also be granted (an update lock indicates the read operation that precedes the exclusive-lock write operation), but no exclusive locks are allowed until all shared locks have been released.

## 1.6.3 Isolation Level 2, Repeatable Read

Level 2 prevents nonrepeatable reads.

These occur when one transaction reads a row and a second transaction modifies that row. If the second transaction commits its change, subsequent reads by the first transaction yield results that are different from the original read. Isolation level 2 is supported only on data-only-locked tables. In a session at isolation level 2, isolation level 3 is also enforced on any tables that use the allpages locking scheme.

T7	Event Sequence	T8
<pre>begin transaction select balance from account where acct_number = 25 select balance from account where acct_number = 25 commit transaction</pre>	<p>T7 and T8 start. T7 queries the balance for one account. T8 updates the balance for that same account. T8 ends. T7 makes same query as before and gets different results.</p> <p>T7 ends.</p>	<pre>begin transaction update account set balance = balance - 100 where acct_number = 25 commit transaction</pre>

If transaction T8 modifies and commits the changes to the `account` table after the first query in T7, but before the second one, the same two queries in T7 produce different results. Isolation level 2 blocks T8 from executing. It would also block a transaction that attempted to delete the selected row.

## 1.6.4 Isolation Level 3, Serializable Reads

Level 3 prevents phantoms.

Phantoms occur when one transaction reads a set of rows that satisfy a search condition, and then a second transaction modifies the data (through an `insert`, `delete`, or `update` statement). If the first transaction repeats the read with the same search conditions, it obtains a different set of rows.

Table 3: Phantoms in Transactions

T9	Event Sequence	T10
<pre>begin transaction select * from account where acct_number &lt; 25 select * from account where acct_number &lt; 25 commit transaction</pre>	<p>T9 and T10 start. T9 queries a certain set of rows. T10 inserts a row that meets the criteria for the query in T9. T10 ends. T9 makes the same query and gets a new row. T9 ends.</p>	<pre>begin transaction insert into account (acct_number, balance) values (19, 500) commit transaction</pre>

If transaction T10 inserts rows into the table that satisfy T9's search condition after T9 executes the first `select`, subsequent reads by T9 using the same query result in a different set of rows.

SAP ASE prevents phantoms by:

- Applying exclusive locks on rows, pages, or tables being changed. It holds those locks until the end of the transaction.
- Applying shared locks on rows, pages, or tables being searched. It holds those locks until the end of the transaction.
- Using range locks or infinity key locks for certain queries on data-only-locked tables.

Holding the shared locks allows SAP ASE to maintain the consistency of the results at isolation level 3. However, holding the shared lock until the transaction ends decreases SAP ASE concurrency by preventing other transactions from getting their exclusive locks on the data.

Table 4: Avoiding Phantoms in Transactions

T11	Event Sequence	T12
<pre>begin transaction select * from account holdlock where acct_number &lt; 25 select * from account holdlock where acct_number &lt; 25 commit transaction</pre>	<p>T11 and T12 start. T11 queries account and holds acquired shared locks. T12 tries to insert row but must wait until T11 releases its locks. T11 makes same query and gets same results. T11 ends and releases its shared locks. T12 gets its exclusive lock, inserts new row, and ends.</p>	<pre>begin transaction insert into account (acct_number, balance) values (19, 500) commit transaction</pre>

In transaction T11, SAP ASE applies shared page locks and holds the locks until the end of T11. (If `account` is a data-only-locked table, and no index exists on the `acct_number` argument, a shared table lock is acquired.) The `insert` in T12 cannot get its exclusive lock until T11 releases its shared locks. If T11 is a long transaction, T12 (and other transactions), may wait for longer periods of time. Use level 3 only when required.

## 1.6.5 SAP ASE Default Isolation Level

SAP ASE's default isolation level is 1, which prevents dirty reads.

SAP ASE enforces isolation level 1 by:

- Applying exclusive locks on pages or tables being changed. It holds those locks until the end of the transaction. Only a process at isolation level 0 can read a page locked by an exclusive lock.
- Applying shared locks on pages being searched. It releases those locks after processing the row, page, or table.

Using exclusive and shared locks allows SAP ASE to maintain the consistency of the results at isolation level 1. Releasing the shared lock after the scan moves off a page improves SAP ASE concurrency by allowing other transactions to obtain their exclusive locks on the data.

## 1.7 Lock Types and Duration During Query Processing

The types and the duration of locks acquired during query processing depend on the type of command, the locking scheme of the table, and the isolation level at which the command is run.

The lock duration depends on the isolation level and the type of query. Lock duration can be:

- Scan duration – locks are released when the scan moves off the row or page, for row or page locks, or when the scan of the table completes, for table locks.
- Statement duration – locks are released when the statement execution completes.

- Transaction duration – locks are released when the transaction completes.

Table 5: Lock Type and Duration Without Cursors

Statement	Isolation Level	Locking Scheme	Table Lock	Data Page Lock	Index Page Lock	Data Row Lock	Duration
select readtext any type of scan	0	Allpages Datapages Datarows	---	---	---	---	No locks are acquired.
	1,2 with noholdlock 3 with noholdlock	Allpages Datapages Datarows	IS IS IS	S * -	S - -	- - *	* Depends on setting of read committed with lock.
	2	Allpages Datapages Datarows	IS IS IS	S S -	S - -	- - S	Locks are released at the end of the transaction.
select via index scan	3,1 with holdlock 2 with holdlock	Allpages Datapages Datarows	IS IS IS	S S -	S - -	- - S	Locks are released at the end of the transaction.
select via table scan	3,1 with holdlock 2 with holdlock	Allpages Datapages Datarows	IS S S	S - -	---	---	Locks are released at the end of the transaction.
insert	0,1,2,3	Allpages Datapages Datarows	IX IX IX	X X -	X - -	- - X	Locks are released at the end of the transaction.
writetext	0,1,2,3	Allpages Datapages Datarows	IX IX IX	X X -	---	- - X	Locks are held on first text page or row; locks released at the end of the transaction.
delete update any type of scan	0,1,2	Allpages Datapages Datarows	IX IX IX	U, X U, X -	U, X - -	- - U, X	"U" locks are released after the statement completes. "IX" and "X" locks are released at the end of the transaction.
delete update via index scan	3	Allpages Datapages Datarows	IX IX IX	U, X U, X -	U, X - -	- - U, X	"U" locks are released after the statement completes. "IX" and "X" locks are released at the end of the transaction.
delete update via table scan	3	Allpages Datapages Datarows	IX X X	U, X - -	---	---	Locks are released at the end of the transaction.

Key: IS intent shared, IX intent exclusive, S shared, U update, X exclusive

Table 6: Lock Type and Duration With Cursors

Statement	Isolation Level	Locking Scheme	Table Lock	Data Page Lock	Index Page Lock	Data Row Lock	Duration
select (without for clause)	0	Allpages Data- tapages Data- rows	---	---	---	---	No locks are acquired.
select... for read only	1 2 with noholdlock 3 with noholdlock	Allpages Data- tapages Data- rows	IS IS IS	S * -	S - -	- - *	* Depends on setting of read committed with lock.
	2, 3 1 with holdlock 2 with holdlock	Allpages Data- tapages Data- rows	IS IS IS	S S -	S - -	- - S	Locks become transactional af- ter the cursor moves out of the page/row. Locks are released at the end of the transaction.
select... for update	1	Allpages Data- tapages Data- rows	IX IX IX	U, X U, X -	X - -	- - U, X	"U" locks are released after the cursor moves out of the page/ row. "IX" and "X" locks are re- leased at the end of the trans- action.
select... for update with shared	1	Allpages Data- tapages Data- rows	IX IX IX	S, X S, X -	X - -	- - S, X	"S" locks are released after the cursor moves out of page/row. "IX" and "X" locks are released at the end of the transaction.
select... for update	2, 3, 1 holdlock 2, holdlock	Allpages Data- tapages Data- rows	IX IX IX	U, X U, X -	X - -	- - U, X	Locks become transactional af- ter the cursor moves out of the page/row. Locks are released at the end of the transaction.
select... for update with shared	2, 3 1 with holdlock 2 with holdlock	Allpages Data- tapages Data- rows	IX IX IX	S, X S, X -	X - -	- - S, X	Locks become transactional af- ter the cursor moves out of the page/row. Locks are released at the end of the transaction.

Key: IS intent shared, IX intent exclusive, S shared, U update, X exclusive

## Related Information

[Locking for Select Queries at Isolation Level 1 \[page 32\]](#)

[Isolation Level 2 and Allpages-locked Tables \[page 33\]](#)

[Locking for Select Queries at Isolation Level 1 \[page 32\]](#)

## 1.7.1 Lock Types During Create Index Commands

Summary table of locks applied by SAP ASE for `create index` statements.

Statement	Table Lock	Data Page Lock
<code>create clustered index</code>	X	-
<code>create nonclustered index</code>	S	-
Function-based indexes	X	X

Key: S = shared, X = exclusive

## 1.7.2 Locking for Select Queries at Isolation Level 1

When a `select` query on an allpages-locked table performs a table scan at isolation level 1, it first acquires a shared intent lock on the table and then acquires a shared lock on the first data page.

It locks the next data page, and drops the lock on the first page, so that the locks “walk through” the result set. As soon as the query completes, the lock on the last data page is released, and then the table-level lock is released. Similarly, during index scans on an allpages-locked table, overlapping locks are held as the scan descends from the index root page to the data page. Locks are also held on the outer table of a join while matching rows from the inner table are scanned.

`select` queries on data-only-locked tables first acquire a shared intent table lock. You can configure locking behavior on data pages and data rows issuing the parameter `read committed with lock`, as follows:

- If `read committed with lock` is set to 0 (the default), then `select` queries read the column values with instant-duration page or row locks. The required column values or pointers for the row are read into memory, and the lock is released. Locks are not held on the outer tables of joins while rows from the inner tables are accessed. This reduces deadlocking and improves concurrency.  
If a `select` query needs to read a row that is locked with an incompatible lock, the query still blocks on that row until the incompatible lock is released. Setting `read committed with lock` to 0 does not affect the isolation level; only committed rows are returned to the user.
- If `read committed with lock` is set to 1, `select` queries acquire shared page locks on datapages-locked tables and shared row locks on datarows-locked tables. The lock on the first page or row is held, then the lock is acquired on the second page or row and the lock on the first page or row is dropped.

You must declare cursors as read-only to avoid holding locks during scans when `read committed with lock` is set to 0. Any implicitly or explicitly updatable cursor on a data-only-locked table holds locks on the current page or row until the cursor moves off the row or page. When `read committed with lock` is set to 1, read-only cursors hold a shared page or row lock on the row at the cursor position.



`read committed with lock` does not affect locking behavior on allpages-locked tables. For more information, see *Reference Manual: Configuration Parameters*.

## 1.7.3 Table Scans and Isolation Levels 2 and 3

Special considerations are made for locking during table scans at isolation levels 2 and 3.

### 1.7.3.1 Table Scans and Table Locks at Isolation Level 3

When a query performs a table scan at isolation level 3 on a data-only-locked table, a shared or exclusive table lock provides phantom protection and reduces the locking overhead of maintaining a large number of row or page locks.

On an allpages-locked table, an isolation level 3 scan first acquires a shared or exclusive intent table lock and then acquires and holds page-level locks until the transaction completes or until the lock promotion threshold is reached and a table lock can be granted.

### 1.7.3.2 Isolation Level 2 and Allpages-locked Tables

On allpages-locked tables, SAP ASE supports isolation level 2 (repeatable reads) by also enforcing isolation level 3 (serializable reads).

If transaction level 2 is set in a session, and an allpages-locked table is included in a query, isolation level 3 is also applied on the allpages-locked tables. Transaction level 2 is used on all data-only-locked tables in the session.

## 1.7.4 When Update Locks Are Not Required

All `update` and `delete` commands on an allpages-locked table first acquire an update lock on the data page and then change to an exclusive lock if the row meets the qualifications in the query.

`update` and `delete` commands on data-only-locked tables do not first acquire update locks when the query:

- Includes search arguments for every key in the index chosen by the query, so that the index unambiguously qualifies the row, and
- Does not contain an `or` clause.

Updates and deletions that meet these requirements immediately acquire an exclusive lock on the data page or data row. This reduces lock overhead.

## 1.7.5 Locking During or Processing

In some cases, queries using `OR` clauses are processed as a union of more than one query.

Although some rows may match more than one of the `OR` conditions, each row must be returned only once. Different indexes can be used for each `OR` clause. If any of the clauses do not have a useful index, the query is performed using a table scan.

The table's locking scheme and the isolation level affect how `OR` processing is performed and the types and duration of locks that are held during the query.

### 1.7.5.1 Processing or Queries for Allpages-locked Tables

If the `OR` query uses the “or” strategy (different `OR` clauses might match the same rows), query processing retrieves the row IDs and matching key values from the index and stores them in a worktable, holding shared locks on the index pages containing the rows.

When all row IDs have been retrieved, the worktable is sorted to remove duplicate values. Then, the worktable is scanned, and the row IDs are used to retrieve the data rows, acquiring shared locks on the data pages. The index and data page locks are released at the end of the statement (for isolation level 1) or at the end of the transaction (for isolation levels 2 and 3).

If the `OR` query has no possibility of returning duplicate rows, no worktable sort is needed. At isolation level 1, locks on the data pages are released as soon as the scan moves off the page.

### 1.7.5.2 Processing or Queries for Data-only-locked Tables

On data-only-locked tables, the type and duration of locks acquired for `OR` queries using the “or” strategy (when multiple clauses might match the same rows) depend on the isolation level.

#### 1.7.5.2.1 Processing or Queries at Isolation Levels 1 and 2

No locks are acquired on the index pages or rows of data-only-locked tables while row IDs are being retrieved from indexes and copied to a worktable.

After the worktable is sorted to remove duplicate values, the data rows are re-qualified when the row IDs are used to read data from the table. If any rows were deleted, they are not returned. If any rows were updated, they are re-qualified by applying the full set of query clauses to them. The locks are released when the row qualification completes, for isolation level 1, or at the end of the transaction, for isolation level 2.

## 1.7.5.2.2 Processing of Queries at Isolation Level 3

Isolation level 3 requires serializable reads. At this isolation level, `or` queries obtain locks on the data pages or data rows during the first phase of `or` processing, as the worktable is being populated. These locks are held until the transaction completes. Re-qualification of rows is not required.

## 1.7.6 Skip Uncommitted inserts During selects

`select` queries on data-only-locked tables do not block on uncommitted insertions when certain conditions are met.

- The table uses datarow locking, and
- The isolation level is 1 or 2.

Under these conditions, scans skip such a row.

The only exception to this rule is if the transaction performing the uncommitted `insert` was overwriting an uncommitted `delete` of the same row done earlier by the same transaction. In this case, scans block on the uncommitted inserted row.

### 1.7.6.1 Skip Uncommitted inserts During deletes, updates, and inserts

`delete` and `update` queries behave the same way as scans do, with regard to uncommitted inserts. When the `delete` or `update` command encounters an uncommitted inserted row with the key value of interest, it skips it without blocking.

The only exception to this rule is if the transaction doing the uncommitted `insert` was overwriting an uncommitted `delete` of the same row done earlier by the same transaction. In this case, `updates` and `deletes` block on the uncommitted inserted row.

Insert queries, upon encountering an uncommitted inserted row with the same key value, raise a duplicate key error if the index is unique.

### 1.7.6.2 Locking during DMLs on Tables with Referential Integrity Constraints

When a transaction inserts a row in a table with a foreign key constraint, it performs a scan at isolation level 2 on the table with the primary key constraint (which is referenced by the table with the foreign key constraint).

SAP ASE performs this scan so the row is not updated or deleted until the transaction commits. Any updates and deletes on the table being scanned block on the referenced key of the row being inserted but is not yet committed.

Similarly, when a transaction attempts to delete a row from a table with a primary key constraint, it performs a scan at isolation level 3 on tables with foreign key constraints that reference this table. SAP ASE does not allow a row insert into these tables until the transaction deleting the row commits.

## 1.7.7 Using Alternative Predicates to Skip Nonqualifying Rows

When a `select` query includes multiple `where` clauses linked with `and`, SAP ASE can apply the qualification for any columns that have not been affected by an uncommitted update of a row.

If the row does not qualify because of one of the clauses on an unmodified column, the row does not need to be returned, so the query does not block.

If the row qualifies when the conditions on the unmodified columns have been checked, and the conditions described below do not allow the query to proceed, then the query blocks until the lock is released.

For example, transaction T15 updates `balance`, while transaction T16 includes `balance` in the result set and in a search clause. However, T15 does not update the `branch` column, so T16 can apply that search argument. It describes a transaction using pseudo columns, which are columns in the index table that define the parameters of the search and provide access to the results data.

Since the `branch` value in the row affected by T15 is not 77, the row does not qualify, and the row is skipped, as shown. If T15 updated a row where `branch` equals 77, a `select` query would block until T15 either commits or rolls back.

T15	Event Sequence	T16
<pre>begin transaction update accounts set balance = 80 where acct_number = 20 and branch = 23 commit transaction</pre>	<p>T15 and T16 start. T15 updates accounts and holds an exclusive row lock. T16 queries accounts, but does not block because the branch qualification can be applied.</p>	<pre>begin transaction select acct_number, balance from accounts where balance &lt; 50 and branch = 77 commit tran</pre>

For `select` queries to avoid blocking when they reference columns in addition to columns that are being updated, all of the following conditions must be met:

- The table must use datarows or datapages locking.
- At least one of the search clauses of the `select` query must be on a column that is among the first 32 columns of the table.
- The `select` query must run at isolation level 1 or 2.
- The configuration parameter `read committed with lock` must be set to 0, the default value.

### Related Information

[Qualify Old and New Values for Uncommitted Updates \[page 38\]](#)

## 1.8 Pseudocolumn-level Locking

During concurrent transactions that involve `select` and `update` commands, pseudo-column-level locking can allow some queries to return values from locked rows, and can allow other queries to avoid blocking on locked rows that do not qualify.

Pseudo-column-level locking can reduce blocking when:

- The `select` query does not reference columns on which there is an uncommitted update.
- The `where` clause of a `select` query references one or more columns affected by an uncommitted update, but the row does not qualify due to conditions in other clauses.
- Neither the old nor the new value of the updated column qualifies, and an index containing the updated column is being used.

### 1.8.1 Select Queries That Do Not Reference the Updated Column

A `select` query on a datarows-locked table can return values without blocking, even though a row is exclusively locked.

This happens when:

- The query does not reference an updated column in the select list or any clauses (`where`, `having`, `group by`, `order by` or `compute`), and
- The query does not use an index that includes the updated column.

Transaction T14 requests information about a row that is locked by T13. However, since T14 does not include the updated column in the result set or as a search argument, T14 does not block on T13's exclusive row lock.

T13	Event Sequence	T14
<pre>begin transaction update accounts set balance = 50 where acct_number = 35 commit transaction</pre>	T13 and T14 start. T13 updates accounts and holds an exclusive row lock. T14 queries the same row in accounts, but does not access the updated column. T14 does not block.	<pre>begin transaction select lname, fname, phone from accounts where acct_number = 35 commit transaction</pre>

If T14 uses an index that includes the updated column (for example, `acct_number`, `balance`), the query blocks trying to read the index row.

For `select` queries to avoid blocking when they do not reference updated columns, all of the following conditions must be met:

- The table must use datarows locking.
- The columns referenced in the `select` query must be among the first 32 columns of the table.
- The `select` query must run at isolation level 1.

- The `select` query must not use an index that contains the updated column.
- The configuration parameter `read committed with lock` must be set to 0, the default value.

## 1.8.2 Qualify Old and New Values for Uncommitted Updates

If a `select` query includes conditions on a column affected by an uncommitted update, and the query uses an index on the updated column, the query can examine both the old and new values for the column.

This occurs:

- If neither the old or new value meets the search criteria, the row can be skipped, and the query does not block.
- If the old value, the new value, or both values qualify, the query blocks. In this table, if the original balance is \$80, and the new balance is \$90, the row can be skipped, as shown. If either of the values is less than \$50, T18 must wait until T17 completes.

T17	Event Sequence	T18
<pre>begin transaction update accounts set balance = balance + 10 where acct_number = 20 commit transaction</pre>	<p>T17 and T18 start. T17 updates accounts and holds an exclusive row lock; the original balance was 80, so the new balance is 90. T18 queries accounts using an index that includes balance. It does not block since balance does not qualify</p>	<pre>begin transaction select acct_number, balance from accounts where balance &lt; 50 commit tran</pre>

For `select` queries to avoid blocking when old and new values of uncommitted updates do not qualify, all of the following conditions must be met:

- The table must use datarows or datapages locking.
- At least one of the search clauses of the `select` query must be on a column that is among the first 32 columns of the table.
- The `select` query must run at isolation level 1 or 2.
- The index used for the `select` query must include the updated column.
- The configuration parameter `read committed with lock` must be set to 0, the default value.

## 2 Snapshot Isolation Level and Locking

In addition to the ANSI-specified isolation level, SAP ASE also offers three additional isolation levels: `statement snapshot`, `transaction snapshot`, and `readonly statement snapshot`. Snapshot isolation is supported only on datarow-locked tables that are enabled for in-memory row storage.

Snapshot isolation levels guarantee that all reads made in a transaction see a consistent snapshot of the database (it reads the last committed values that existed at the time it started), and the transaction itself successfully commits only if no updates it has made conflict with any concurrent update made since that snapshot.

Snapshot isolation levels are used with multiversion concurrency control (MVCC), which allows the server to lock rows for writing in one session while granting access to unaltered versions of these rows in another session. That is, reads never wait for writes, and writes never wait for reads, alleviating concurrency.

MVCC provides multiple versions of a single row, and snapshot isolation allows the server to access a version of this row at a specific snapshot of time. The server uses versions of the rows with time stamps hosted in the IMRS, allowing for in-memory versioning, to provide snapshot isolation. `select` statements can access their version of the row from the IMRS, without being blocked by or blocking concurrent users updating the same rows.

Use MVCC and snapshot isolation levels in conjunction with the in-memory row storage feature. See the *In-Memory Database Users Guide* for more information about configuring SAP ASE for row storage.

Once a table is enabled for snapshot isolation, any change to a data row causes the server to create a new version of the data row. Since multiple versions are available and there is a well-defined rule about which transaction sees which data, locking is not required to qualify the data rows. The scans or `select` queries with snapshot isolation-level scans need not acquire any transactional lock on qualified data rows. This example, which does not use snapshot isolation, describes how an update can block a `select` query due to the locks it acquires:

Session 1	Session 2	Comments
	<pre>begin tran</pre>	
	<pre>update t1 set t1.a = 5 where t1.b = 'target'</pre>	
<pre>select * from t1</pre>		The scan for the <code>select</code> in session 1 blocks since the update in session 2 has acquired locks on some rows.
	<pre>commit tran</pre>	
<pre>select returns the results</pre>		The <code>select</code> in session 1 returns results only after session 2 commits.

However, if you configure the session for snapshot isolation, the `update` no longer acquires the locks, and the `select` proceeds:

Session 1	Session 2	Comments
<pre>set transaction isolation statement snapshot</pre>		
	<pre>begin tran</pre>	
	<pre>update t1 set t1.a = 5 where t1.b = 'target'</pre>	
<pre>select * from t1</pre> select returns the results.		The scan for <code>select</code> in session 1 returns the results immediately and does not block while it waits for the <code>update</code> transaction in session 2 to complete. The value returned for <code>t1.a</code> is the pre-updated value for rows where <code>t2.b = 'target'</code> .
	<pre>commit tran</pre>	

### Note

If some tables involved in a transaction are not MVCC or on-disk MVCC-enabled, the transaction switches to the default isolation mode. That is, for `statement snapshot` it will be isolation level 1 and for `transaction snapshot` it will be isolation level 2.

Considerations for locks and updates for the snapshot isolation levels:

- `statement snapshot` - acquires locks on the rows as they are qualified during the scan and before they get modified. The `update` keeps the locks acquired during previous passes in case the command must re-execute, improving the chances of completing the `update`. Updates qualify the version of the row according to the timestamp, and if it qualifies, verifies whether it is the latest committed version of the row. If not, the update acquires a new timestamp and re-executes the statement. This cycle repeats until the evaluation succeeds with the new timestamp, and the row is updated with latest committed version. Since this is an `update` operation, it works under an exclusive lock, and any other `update` or `delete` queries from other session must wait (`selects` queries, however, can proceed).
- `transaction snapshot` - the statement—not the transaction— gets rolled back for a write conflict.
- `readonly statement snapshot` - since scans are performed on the latest committed versions and not with timestamp, there are no write-conflicts, and qualified rows are immediately locked, similar to non-snapshot isolation levels.



# 3 Locking Configuration and Tuning

SAP ASE includes a number of lock types and a number of commands that can affect locking.

## 3.1 Locks and Performance

Locking affects the SAP ASE performance by limiting concurrency. An increase in the number of simultaneous users may increase lock contention, which decreases performance.

Locks affect performance when:

- Processes wait for locks to be released. Any time a process waits for another process to complete its transaction and release its locks, overall response time and throughput are affected.
- Transactions result in frequent deadlocks. A deadlock causes one transaction to be aborted, and the transaction must be restarted by the application. If deadlocks occur often, the throughput of applications is severely affected.  
To help reduce deadlock frequency, change the locking scheme to datapages or datarows locking, or redesign the way transactions access data.
- Creating indexes locks tables. Creating a clustered index locks all users out of the table until the index is created; creating a nonclustered index locks out all updates until it is created.  
Either way, create indexes when there is little activity on your server.
- Turning off delayed deadlock detection causes spinlock contention.  
Setting `deadlock checking period` to 0 causes more frequent deadlock checking. The deadlock detection process holds spinlocks on the lock structures in memory while it looks for deadlocks.  
In a high transaction production environment, do not use the `deadlock checking period` parameter.

### 3.1.1 sp\_sysmon and sp\_object\_stats Usage

Many of the following sections suggest that you change configuration parameters to reduce lock contention.

Use `sp_object_stats` or `sp_sysmon` to determine whether lock contention is a problem. Then use the stored procedures to determine how tuning to reduce lock contention affects the system.

See "Lock management" in *Performance and Tuning Series: Monitoring SAP ASE with sp\_sysmon* for more information about using `sp_sysmon` to view lock contention.

If lock contention is a problem, you can use SAP ASE Monitor or the monitoring tables to pinpoint locking problems by checking locks per object.

## Related Information

[Identify Tables Where Concurrency is a Problem \[page 72\]](#)

### 3.1.2 Reduce Lock Contention

Lock contention can impact SAP ASE throughput and response time. Make sure you are using the correct locking during database design (for example, to avoid joining a high number of tables during queries), and monitor locking during application design.

Address locking contention by changing the locking scheme for tables with high contention, or redesigning the application or tables that have the highest lock contention. For example:

- Add indexes to reduce contention, especially for deletions and updates.
- Keep transactions short to reduce the time that locks are held.
- Check for contention “hot spots,” especially insertions on allpages-locked heap tables (a heap table is a table that has no clustered index).

Additionally, you can reduce spinlock contention in high-performance situations by using the transactional memory feature available with the MemScale option. See [Transactional Memory \[page 45\]](#).

#### 3.1.2.1 Reducing Contention Between Updates and Selects

Certain tasks help reduce lock contention between `update` and `select` queries.

- Use datarows or datapages locking for tables with lock contention caused by `update` and `select` commands.
- If tables have more than 32 columns, make the first 32 columns the columns most frequently used as search arguments and in other query clauses.
- Select only needed columns. Avoid using `select *` when all columns are not needed by the application.
- Use any available predicates for `select` queries. When a table uses datapages locking, the information about updated columns is kept for the entire page, so that if a transaction updates some columns in one row, and other columns in another row on the same page, any `select` query that needs to access that page must avoid using any of the updated columns.

#### 3.1.2.2 Lock Management Enhancements

SAP ASE version 16.0 and later includes several enhancements to lock management.

Spinlocks in versions of SAP ASE earlier than 16.0 occasionally result in lock contention. Reduce lock contention by optimizing the following areas:

- Engine lock transfer – Improves the transfers of locks between global pool and engine local caches.
- Engine lock caching – Optimizes the number of locks an engine can cache locally by:

- Increasing the default engine local cache size
- Increasing the transfer size of locks from global to local caches.
- Improves lock transfers between local and global by using of blocks of locks instead of individual locks
- Draining or reclaiming locks from local to global caches less frequently
- Lock promotion - Tracks repeatedly failed lock promotion attempts, and disables lock promotion for the DML statement incurring the failed lock promotion after a number of attempts.
- Log semaphore locks - Avoids taking locks for log semaphores since only one lock can be held by the `semawait`.
- Deadlock checking - Ensures that specifying a small value for the `deadlock checking period` never results in a value less than 1, and that deadlock checks are performed on a dedicated service thread
- Hot DOL tables - Allows DOL tables to be hot tables, which alleviates high table lock contention

These features are intended to enhance performance: you should not notice any performance degradation when SAP ASE uses these enhancements. The lock management enhancements are enabled by default, and you need not to perform any configuration to enable these enhancements.

In high performance, high core situations, the main obstruction to scaling is that many threads are busy waiting on spinlocks. To reduce spinlock contention in these instances, use the transactional memory feature.

#### **i Note**

Transactional memory is supported only on Intel Haswell EX processors on Linux.

Enable transactional memory by first enabling the MemScale option. See *SAP ASE Options* in the Installation Guide for your platform for information about enabling the Database MemScale option. Then, set the `enable transactional memory` configuration parameter.

### **3.1.2.3 Add Indexes to Reduce Contention**

For data-only-locked tables, an `update` or `delete` statement that has no useful index on its search arguments results in a table scan that holds an exclusive table lock for the entire scan time.

If the data modification task also updates other tables:

- It can be blocked by `select` queries or other updates.
- It may be blocked and have to wait while holding large numbers of locks.
- It can block or deadlock with other tasks.

Creating a useful index for the query allows the data modification statement to use page or row locks, improving concurrent access to the table. If you cannot create an index for a lengthy `update` or `delete` transaction, you can perform the operation in a cursor, with frequent `commit transaction` statements to reduce the number of page locks.

### 3.1.2.4 Retain Short Transactions

Keep any transaction that acquires locks as short as possible. In particular, avoid transactions that wait for user interaction while holding locks.

Table 7: Examples

	With Page-level Locking	With Row-level Locking
<pre>begin tran</pre>		
<pre>select balance from account holdlock where acct_number = 25</pre>	<i>Intent shared table lock Shared page lock</i>	<i>Intent shared table lock Shared row lock</i>
	If the user goes to lunch now, no one can update rows on the page that holds this row.	If the user goes to lunch now, no one can update this row.
<pre>update account set balance = balance + 50 where acct_number = 25</pre>	<i>Intent exclusive table lock Update page lock on data page followed by exclusive page lock on data page</i>	<i>Intent exclusive table lock Update row lock followed by exclusive row lock.</i>
	No one can read rows on the page that holds this row.	No one can read this row.
<pre>commit tran</pre>		

Avoid network traffic as much as possible within transactions. The network is slower than SAP ASE. The example below shows a transaction executed from `isql`, sent as two packets.

<pre>begin tran update account set balance = balance + 50 where acct_number = 25 go</pre>	<i>isql batch sent to SAP ASE Locks held waiting for commit</i>
<pre>update account set balance = balance - 50 where acct_number = 45 commit tran go</pre>	<i>isql batch sent to SAP ASE Locks released</i>

Keeping transactions short is especially crucial for data modifications that affect nonclustered index keys on allpages-locked tables.

Nonclustered indexes are dense: the level above the data level contains one row for each row in the table. All `inserts` and `deletes` to the table, and any updates to the key value, affect at least one nonclustered index page, and adjoining pages in the page chain, if a page split or page shrink takes place.

While locking a data page may slow access for a small number of rows, locks on frequently used index pages can block access to a much larger set of rows.

### 3.1.2.5 Avoid Hot Spots

Hot spots occur when all updates take place on a certain page, as in an allpages-locked heap table, where all insertions happen on the last page of the page chain.

For example, an unindexed history table that is updated by everyone always has lock contention on the last page. This sample output from `sp_sysmon` shows that 11.9% of the inserts on a heap table need to wait for the lock:

Last Page Locks on Heaps				
Granted	3.0	0.4	185	88.1 %
Waited	0.4	0.0	25	11.9 %

To avoid this:

- Change the lock scheme to datapages or datarows locking.  
Since these locking schemes do not have chained data pages, they can allocate additional pages when blocking occurs for inserts.
- Partition the table using the round-robin strategy. Partitioning a heap table creates multiple page chains in the table, and, therefore, multiple last pages for insertions.  
Concurrent inserts to the table are less likely to block one another, since multiple last pages are available. Partitioning improves concurrency for heap tables without creating separate tables for different groups of users.  
See “Improving insert performance with partitions” in *Performance and Tuning Series: Physical Database Tuning* for information about partitioning tables.
- Create a clustered index to distribute updates across the data pages in the table.  
Like partitioning, this creates multiple insertion points for the table. However, it also introduces overhead for maintaining the physical order of the table’s rows.

### 3.1.2.6 Transactional Memory

In high performance, high core situations, use the transactional memory feature to reduce spinlock contention.

Transactional memory is included with the MemScale option and is currently supported on Haswell and Broadwell processors on Linux.

Enable transactional memory by first setting the `enable mem scale` configuration parameter. Then, set the `enable transactional memory` configuration parameter.

To find out if your machine supports Transactional Synchronization Extensions (TSX):

1. Enter the following in the command line to query the model number:

```
cat /proc/cpuinfo | grep 'model name' | head -1
```

An example of the return value is:

```
model name : Intel(R) Xeon(R) CPU E7-4880 v2 @ 2.50GHz
```

2. Go to <http://ark.intel.com/> and enter the model number in the *Search specification* field. In the example above, the model number is E7-4880.
3. Select the entry with the exact model and version number.

4. In the specification form, note the *Code Name*. Code names Haswell or Broadwell indicate that the machine supports TSX. Code names Sandy Bridge, Ivy Bridge, or Westmere indicate that the machine does not support TSX. For other names, consult Intel directly.

Additional information is available here: <https://software.intel.com/en-us/blogs/2013/06/07/web-resources-about-intel-transactional-synchronization-extensions>

### 3.1.3 Additional Locking Guidelines

Locking guidelines that can help reduce lock contention and speed performance.

- Use the lowest level of locking required by each application. Use isolation level 2 or 3 only when necessary. Updates by other transactions may be delayed until a transaction using isolation level 3 releases any of its shared locks at the end of the transaction.  
Use isolation level 3 only when nonrepeatable reads or phantoms may interfere with results.  
If only a few queries require isolation level 3, use the `holdlock` keyword or the `at isolation serializing` clause in those queries rather than using `set transaction isolation level 3` for the entire transaction.  
If most queries in the transaction require isolation level 3, use `set transaction isolation level 3`, but use `noholdlock` or `at isolation read committed` in the queries that can execute at isolation level 1.
- To perform mass insertions, updates, or deletions on active tables, reduce blocking by performing the operation inside a stored procedure using a cursor, with frequent commits.
- If the application must return a row, wait for user interaction, and then update the row, consider using timestamps and the `tsequal` function rather than `holdlock`.
- If you use third-party software, check the locking model in applications carefully for concurrency problems.

Other tuning efforts can also help reduce lock contention. For example, if a process holds locks on a page, and must perform a physical I/O to read an additional page, the process holds the lock much longer than it would if the additional page were already in cache. In this case, better cache utilization or the use of large I/O can reduce lock contention. You can also reduce lock contention by improving indexing and distributing physical I/O evenly across disks.

### 3.1.4 Improved Concurrency for Partition-Level Online Operations

Certain partition-level operations can concurrently operate on different partitions of a table. DML can also concurrently operate on the table while the partition-level online operation is running.

These include:

- `alter table ... split partition`
- `alter table ... merge partition`
- `alter table ... move partition`
- `alter table ... drop partition`
- `truncate partition`

- `dbcc checkindex`
- `dbcc checktable`
- `dbcc tablealloc`
- `dbcc indexalloc`

## 3.2 Lock Configuration and Promotion Thresholds

A system administrator can configure locks and lock promotion thresholds.

- The total number of locks available to processes on SAP ASE
- The size of the lock hash table and the number of spinlocks that protect the page/row lock hash table, table lock hash table, and address lock hash table
- The server-wide lock timeout limit, and the lock timeout limit for distributed transactions
- Lock promotion thresholds, server-wide, for a database or for particular tables
- The number of locks available per engine and the number of locks transferred between the global free lock list and the engines

### 3.2.1 Lock Promotion

Table lock promotion promotes locks from fine-grained locks to table locks. Partition lock promotion promotes locks from fine-grained locks to partition locks.

For partition lock promotion to occur, set the partition lock promotion threshold to a nonzero value.

Partition locks use the same semantics as table locks. Page or row locks belonging to a partition under a single partition scan that exceeds its lock promotion threshold can then trigger lock promotion to a partition lock.

When a page or row lock is acquired with an unknown partition, lock promotion to the partition lock is completely disabled. In these situations, locks can only be promoted to table level.

SAP ASE supports two different types of lock promotion:

- Row or page to table lock – if a task acquires locks within a single scan of a table on as many number of rows or pages that exceed the table-level lock promotion threshold, then SAP ASE tries to acquire shared table or exclusive table locks on the corresponding table and replace all existing rows or pages in that table. Table-level lock promotion is also triggered when row or page locks are acquired with an unknown ID when the owning partition is not known for the lock promotion.
- Row or page to partition lock – during partition lock promotion the appropriate shared or exclusive partition lock is acquired and all of the fine-grained locks acquired as part of the scan (or DML) and belonging to the partition are released.
  - Partition lock promotion promotes shared fine-grained locks to shared partition locks.
  - Partition lock promotion promotes exclusive fine-grained locks to exclusive partition locks.

## 3.2.2 Configuring the SAP ASE Lock Limit

By default, SAP ASE is configured with 10000 locks. System Administrators can use `sp_configure` to change this limit.

For example:

```
sp_configure "number of locks", 25000
```

You may also need to adjust the `sp_configure` parameter `max memory`, since each lock uses memory.

The number of locks required by a query can vary widely, depending on the locking scheme and on the number of concurrent and parallel processes and the types of actions performed by the transactions. Configuring the correct number for your system is a matter of experience and familiarity with the system.

Start with 20 locks for each active concurrent connection, plus 20 locks for each worker process. Consider increasing the number of locks if:

- You use datarows locking
- Queries run at isolation level 2 or 3, or use `serializable` or `holdlock`
- Parallel query processing is enabled, especially for isolation level 2 or 3 queries
- You perform many multirow updates
- You increase lock promotion thresholds

### 3.2.2.1 Estimate Number of Locks for Data-only-locked Tables

Changing to data-only locking may require more locks or may reduce the number of locks required.

- Tables using datapages locking require fewer locks than tables using allpages locking, since queries on datapages-locked tables do not acquire separate locks on index pages.
- Tables using datarows locking can require a large number of locks. Although no locks are acquired on index pages for datarows-locked tables, data modification commands that affect many rows may hold more locks.

Queries running at transaction isolation level 2 or 3 can acquire and hold very large numbers of row locks.



### 3.2.2.1.1 insert Commands and Locks

An `insert` with `allpages` locking requires  $\langle N \rangle + 1$  locks, where  $\langle N \rangle$  is the number of indexes. The same insert on a data-only-locked table locks only the data page or data row.

### 3.2.2.1.2 select Queries and Locks

Scans at transaction isolation level 1, with `read committed with lock` set to hold locks (1), acquire overlapping locks that roll through the rows or pages, so they hold, at most, two data page locks at a time.

However, transaction isolation level 2 and 3 scans, especially those using `datarows` locking, can acquire and hold very large numbers of locks, especially when running in parallel. Using `datarows` locking, and assuming no blocking during lock promotion, the maximum number of locks that might be required for a single table scan is:

```
row lock promotion HWM * parallel_degree
```

If lock contention from exclusive locks prevents scans from promoting to a table lock, the scans can acquire a very large number of locks.

Instead of configuring the number of locks to meet the extremely high locking demands for queries at isolation level 2 or 3, consider changing applications that affect large numbers of rows to use the `lock table` command. This command acquires a table lock without attempting to acquire individual page locks.

## Related Information

[lock table \[page 84\]](#)

### 3.2.2.1.3 Data Modification Commands and Locks

For tables that use the `datarows`-locking scheme, data modification commands can require many more locks than data modification on `allpages`- or `datapages`-locked tables.

For example, a transaction that performs a large number of inserts into a heap table may acquire only a few page locks for an `allpages`-locked table, but requires one lock for each inserted row in a `datarows`-locked table. Similarly, transactions that update or delete large numbers of rows may acquire many more locks with `datarows` locking.

## 3.2.2.2 Limiting User Locks Per Session

Set `lock_count` resource limit to restrict the number of logical locks used simultaneously by a user process. The `lock_count` limit prevents a user or application from draining locks in reserve, preventing the server from entering an “out of locks” state.

See "Limiting User Locks Per Session" in *System Administration Guide: Volume 2* and `sp_add_resource_limit` procedure documentation in the *Reference Manual: Procedures*.

## 3.2.3 Set Lock Promotion Thresholds

The lock promotion thresholds set the number of page or row locks permitted by a task or worker process before SAP ASE attempts to escalate to a table lock on the object.

You can set lock promotion thresholds at the server-wide level, at the database level, and for individual tables.

Configuring the thresholds higher reduces the chance of queries acquiring table locks, especially for very large tables where queries lock hundreds of data pages.

### i Note

Lock promotion is always two-tiered: from page locks to partition or table locks or from row locks to partition or table locks. Row locks are never promoted to page locks.

## 3.2.3.1 Lock Promotion and Scan Sessions

Lock promotion occurs on a per-scan-session basis.

A *scan session* is how SAP ASE tracks scans of tables within a transaction. A single transaction can have more than one scan session for the following reasons:

- A table may be scanned more than once inside a single transaction in the case of joins, subqueries, `exists` clauses, and so on. Each scan of the table is a scan session.
- A query executed in parallel scans a table using multiple worker processes. Each worker process has a scan session.

A scan session may scan data from more than one partition. Lock promotion is based on the number of page or row locks acquired across all the partitions accessed in the scan.

A table lock is more efficient than multiple page or row locks when an entire table might eventually be needed. At first, a task acquires page or row locks, then attempts to escalate to a table lock when a scan session acquires more page or row locks than the value set by the lock promotion threshold.

Since lock escalation occurs on a per-scan-session basis, the total number of page or row locks for a single transaction can exceed the lock promotion threshold, as long as no single scan session acquires more than the lock promotion threshold number of locks. Locks may persist throughout a transaction, so a transaction that includes multiple scan sessions can accumulate a large number of locks.

Lock promotion cannot occur if another task holds locks that conflict with the type of table lock needed. For instance, if a task holds any exclusive page locks, no other process can promote to a table lock until the exclusive page locks are released.

When lock promotion is denied due to conflicting locks, a process can accumulate page or row locks in excess of the lock promotion threshold and may exhaust all available locks in SAP ASE.

The lock promotion parameters are:

- For allpages-locked tables and datapages-locked tables, `page lock promotion HWM`, `page lock promotion LWM`, and `page lock promotion PCT`.
- For datarows-locked tables, `row lock promotion HWM`, `row lock promotion LWM`, and `row lock promotion PCT`.

The abbreviations in these parameters are:

- HWM – high water mark
- LWM – low water mark
- PCT – percent

### 3.2.3.2 Lock Promotion High Water Mark

`page lock promotion HWM` and `row lock promotion HWM` set a maximum number of page or row locks allowed on a table before SAP ASE attempts to escalate to a table lock. The default value is 200.

When the number of locks acquired during a scan session exceeds this number, SAP ASE attempts to acquire a table lock.

Setting the high water mark to a value greater than 200 reduces the chance of any task or worker process acquiring a table lock on a particular table. For example, if a process updates more than 200 rows of a very large table during a transaction, setting the lock promotion high water mark higher keeps this process from attempting to acquire a table lock.

Setting the high water mark to less than 200 increases the chances of a particular task or worker process acquiring a table lock.

### 3.2.3.3 Lock Promotion Low Water Mark

`page lock promotion LWM` and `row lock promotion LWM` set a minimum number of locks allowed on a table before SAP ASE can acquire a table lock. The default value is 200.

SAP ASE cannot acquire a table lock until the number of locks on a table is equal to the low water mark.

The low water mark must be less than or equal to the corresponding high water mark.

Setting the low water mark to a very high value decreases the chance for a particular task or worker process to acquire a table lock, which uses more locks for the duration of the transaction, potentially exhausting all available locks in SAP ASE. The possibility of all locks being exhausted is especially high with queries that update a large number of rows in a datarows-locked table, or that select large numbers of rows from datarows-locked tables at isolation levels 2 or 3.

If conflicting locks prevent lock promotion, you may need to increase the value of the `number of locks` configuration parameter.

### 3.2.3.4 Lock Promotion Percent

`page lock promotion PCT` and `row lock promotion PCT` set the percentage of locked pages or rows.

This is based on the table size above which SAP ASE attempts to acquire a table lock when the number of locks is between the `lock promotion HWM` and the `lock promotion LWM`.

The default value is 100.

SAP ASE attempts to promote page locks to a table lock or row locks to a table lock when the number of locks on the table exceeds:

$$(\text{PCT} * \text{number of pages or rows in the table}) / 100$$

Setting `lock promotion PCT` to a very low value increases the chance of a particular user transaction acquiring a table lock.

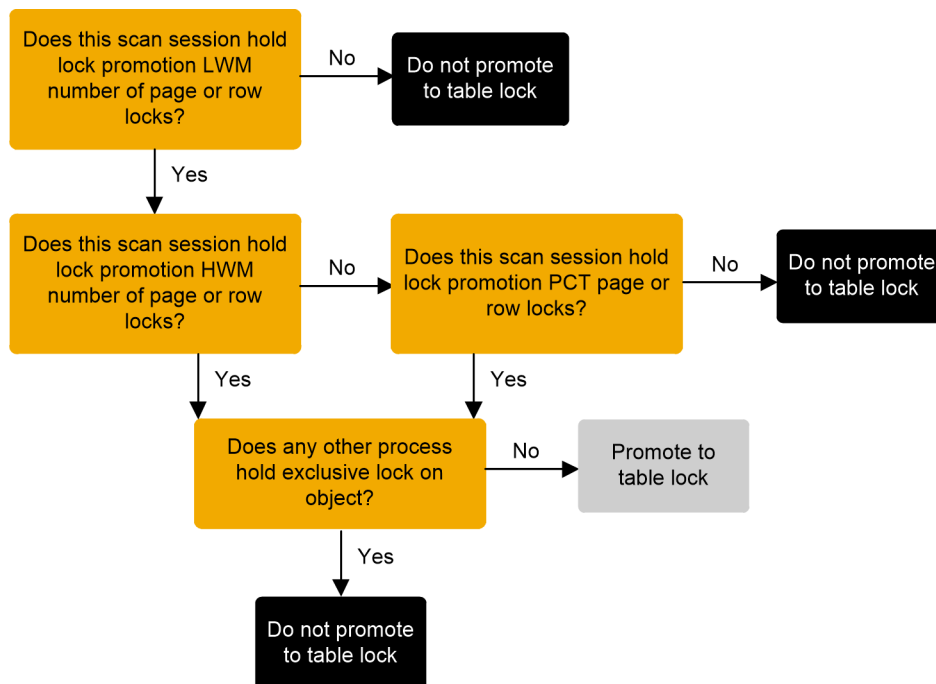

### 3.2.3.5 Set Server-wide Lock Promotion Thresholds

Use `sp_setpglockpromote` or `sp_setpglockpromote_ptn` to set the server-wide lock promotion thresholds.

The following command sets the server-wide `page lock promotion LWM` to 100, the `page lock promotion HWM` to 2000, and the `page lock promotion PCT` to 50 for all `datapages-locked` and `allpages-locked` tables:

```
sp_setpglockpromote "server", null, 100, 2000, 50
```

In this example, the task does not attempt to promote to a table lock unless the number of locks on the table is between 100 and 2000.

If a command requires more than 100 but less than 2000 locks, SAP ASE compares the number of locks to the percentage of locks on the table.

If the number of locks is greater than the number of pages resulting from the percentage calculation, SAP ASE attempts to issue a table lock.

`sp_setrowlockpromote` sets the configuration parameters for all `datarows-locked` tables:

```
sp_setrowlockpromote "server", null, 300, 500, 50
```

The default values for lock promotion configuration parameters are likely to be appropriate for most applications.

The `sp_setpglockpromote_ptn` system procedure sets partition-lock promotion thresholds at the server, database, and table level.

This example sets the server-wide partition lock promotion threshold values `LWM` to 200, the `HWM` to 300, and the `PCT` to 50:

```
sp_setpglockpromote_ptn "server", NULL, 200, 300, 50
```

The `sp_setrowlockpromote_ptn` system procedure sets partition-lock promotion thresholds for `datarows-locked` partitions at the server, database, and table level. For example:

```
sp_setrowlockpromote_ptn "server", NULL, 100, 1000, 100
```

### 3.2.3.6 Set the Lock Promotion Threshold for a Table or Database

To configure lock promotion values for an individual table or database, initialize all three lock promotion thresholds.

For example:

```
sp_setpglockpromote "table", titles, 100, 2000, 50
```

```
sp_setrowlockpromote "table", authors, 300, 500, 50
```

```
sp_setrowlockpromote_ptn "table", "pubs2..titles", 500, 700, 10
```

After the values are initialized, you can change any individual value. For example, to change the lock promotion PCT only:

```
sp_setpglockpromote "table", titles, null, null, 70
```

```
sp_setrowlockpromote "table", authors, null, null, 50
```

```
sp_setrowlockpromote_ptn "table", "pubs2..titles", null, null, 10
```

To configure values for a database, use:

```
sp_setpglockpromote "database", pubs3, 1000, 1100, 45
```

```
sp_setrowlockpromote "database", pubs3, 1000, 1100, 45
```

```
sp_setrowlockpromote_ptn "database", master, 1000, 1100, 45
```

### 3.2.3.7 Precedence of Settings

You can change the lock promotion thresholds for any user database or for an individual table. Settings for an individual table override the database or server-wide settings; settings for a database override the server-wide values.

Server-wide values for lock promotion apply to all user tables on the server, unless the database or tables have lock promotion values configured.

### 3.2.3.8 Dropping Database and Table Settings

To remove table, partition, or database lock promotion thresholds for table lock promotion, use `sp_droplockpromote` or `sp_droprowlockpromote`.

Use `sp_droplockpromote_ptn` or `sp_droprowlockpromote_ptn` to remove partition-lock promotion thresholds.

When you drop a database's lock promotion thresholds, tables that do not have lock promotion thresholds configured use the server-wide values. When you drop a table's lock promotion thresholds, SAP ASE uses the database's lock promotion thresholds, if they have been configured, or the server-wide values, if the lock promotion thresholds have not been configured. You cannot drop server-wide table lock promotion thresholds.

### 3.2.3.9 `sp_sysmon` Usage While Tuning Lock Promotion Thresholds

Use `sp_sysmon` to see how many times lock promotions take place and the types of promotions they are.

If there is a problem, look for signs of lock contention in the “Granted” and “Waited” data in the “Lock Detail” section of `sp_sysmon` output.

See “Lock promotions” and “Lock detail” in *Performance and Tuning Series: Monitoring SAP ASE with `sp_sysmon`*.

If lock contention is high and lock promotion is frequent, consider changing the lock promotion thresholds for the tables involved.

## 3.3 Choosing the Locking Scheme for a Table

In general, choose a lock scheme for a new table based on the likelihood that applications will experience lock contention on the table.

### Context

Whether to change the locking scheme for an existing table can be based on contention measurements on the table, but should also take application performance into account.

Here are some typical situations and general guidelines for choosing the locking scheme:

- Applications require clustered access to data rows due to range queries or `order by` clauses. Allpages locking provides more efficient clustered access than data-only-locking. Rows may not be returned in key order of the clustered index for queries.
- A large number of applications access 10 to 20% of the data rows, with many `update` and `select` commands on the same data.  
Use datarows or datapages locking to reduce contention, especially on tables that have the highest contention.
- The table is a heap table that will have a high rate of inserts.  
Use datarows locking to avoid contention. If the number of rows inserted per batch is high, datapages locking is also acceptable. Allpages locking has more contention for the “last page” of heap tables.
- Applications need to maintain an extremely high transaction rate; contention is likely to be low.  
Use allpages locking; less locking and latching overhead yields improved performance.

## 3.3.1 Analyzing Existing Applications

Analyze existing applications if blocking and deadlock problems are experienced.

### Procedure

1. Check for deadlocks and lock contention:
  - Use `sp_object_stats` to determine the tables where blocking is a problem.
  - Identify the tables involved in the deadlock, either using `sp_object_stats` or by enabling the `print deadlock information` configuration parameter.
2. If the table uses allpages locking and has a clustered index, ensure that performance of the modified clustered index structure on data-only-locked tables will not hurt performance.
3. If the table uses allpages locking, convert the locking scheme to datapages locking to determine whether that solves the concurrency problem.
4. Re-run the concurrency tests. If concurrency is still an issue, change the locking scheme to datarows locking.

### Related Information

[Tables where Clustered Index Performance Must Remain High \[page 58\]](#)

## 3.3.2 Choosing a Locking Scheme Based on Contention Statistics

If the locking scheme for the table is allpages, the lock statistics reported by `sp_object_stats` include both data page and index lock contention.

If lock contention totals 15% or more for all shared, update, and exclusive locks, `sp_object_stats` recommends changing to datapages locking. Make the recommended change, and run `sp_object_stats` again.

If contention using datapages locking is more than 15%, `sp_object_stats` recommends changing to datarows locking. This two-phase approach is based on these characteristics:

- Changing from allpages locking to either data-only-locking scheme is time consuming and expensive, in terms of I/O cost, but changing between the two data-only-locking schemes is fast and does not require copying the table.
- Datarows locking requires more locks and consumes more locking overhead.  
If your applications experience little contention after you convert high-contending tables to use datapages locking, you do not need to incur the locking overhead of datarows locking.



## i Note

The number of locks available to all processes on the server is limited by the `number of locks` configuration parameter.

Changing to datapages locking reduces the number of locks required, since index pages are no longer locked.

Changing to datarows locking can increase the number of locks required, since a lock is needed for each row.

When examining `sp_object_stats` output, look at tables that are used together in transactions in your applications. Locking on tables that are used together in queries and transactions can affect the locking contention of the other tables.

Reducing lock contention on one table could ease lock contention on other tables as well, or it could increase lock contention on another table that was masked by blocking on the first table in the application. For example:

- Lock contention is high for two tables that are updated in transactions involving several tables. Applications first lock `TableA`, then attempt to acquire locks on `TableB`, and block, holding locks on `TableA`. Additional tasks running the same application block while trying to acquire locks on `TableA`. Both tables show high contention and high wait times. Changing `TableB` to data-only locking may alleviate the contention on both tables.
- Contention for `TableT` is high, so its locking scheme is changed to a data-only locking scheme. Re-running `sp_object_stats` now shows contention on `TableX`, which had shown very little lock contention. The contention on `TableX` was masked by the blocking problem on `TableT`.

If your application uses many tables, you may want to convert your set of tables to data-only locking gradually, by changing only those tables with the highest lock contention. Then test the results of these changes by re-running `sp_object_stats`.

Run your usual performance monitoring tests both before and after you make the changes.

## Related Information

[Estimate Number of Locks for Data-only-locked Tables \[page 48\]](#)

### 3.3.3 Monitoring and Managing Tables After Conversion

Manage and monitor your tables after you have converted them in an application to a data-only-locking scheme.

#### Context

- Check query plans and I/O statistics, especially for those queries that use clustered indexes.
- Monitor the tables to learn how changing the locking scheme affects:
  - Cluster ratios, especially for tables with clustered indexes
  - The number of forwarded rows in the table

### 3.3.4 Applications Not Likely to Benefit from Data-only Locking

Certain tables and application types may get little benefit from converting to data-only locking, or may require additional management after the conversion.

#### 3.3.4.1 Tables where Clustered Index Performance Must Remain High

If queries with high performance requirements use clustered indexes to return large numbers of rows in index order, you may see performance degradation if you change these tables to use data-only locking. Clustered indexes on data-only-locked tables are structurally the same as nonclustered indexes.

Placement algorithms keep newly inserted rows close to existing rows with adjacent values, as long as space is available on nearby pages.

Performance for a data-only-locked table with a clustered index should be close to the performance of the same table with allpages locking immediately after a `create clustered index` command or a `reorg rebuild` command, but performance, especially with large I/O, declines if cluster ratios decline because of insertion and forwarded rows.

Performance remains high for tables that do not experience many insertions. On tables that get many insertions, a System Administrator may need to drop and re-create the clustered index or run `reorg rebuild` more frequently.

Using space management properties such as `fillfactor`, `exp_row_size`, and `reservepagegap` can help reduce the frequency of maintenance operations. In some cases, using the allpages-locking scheme for the table, even if there is some contention, may provide better performance for queries performing clustered index scans than using data-only locking for the tables.

### 3.3.4.2 Tables with Maximum-length Rows

Data-only-locked tables require more overhead per page and per row than allpages-locked tables, so the maximum row size for a data-only-locked table is slightly shorter than the maximum row size for an allpages-locked table.

For tables with fixed-length columns only, the maximum row size is 1958 bytes of user data for data-only-locked tables. Allpages-locked tables allow a maximum of 1960 bytes.

For tables with variable-length columns, subtract 2 bytes for each variable-length column (this includes all columns that allow null values). For example, the maximum user row size for a data-only-locked table with 4 variable-length columns is 1950 bytes.

If you try to convert an allpages-locked table that has more than 1958 bytes in fixed-length columns, the command fails as soon as it reads the table schema.

When you try to convert an allpages-locked table with variable-length columns, and some rows exceed the maximum size for the data-only-locked table, the `alter table` command fails at the first row that is too long to convert.

## 3.4 Optimistic Index Locking

Optimistic index locking can resolve increased contention on some important resources, such as the spinlocks that guard address locks on the root page of an index partition.

Applications where this amount of contention might occur are typically those in which:

- Access to a specified index constitutes a significant portion of the transaction profile, and many users are concurrently executing the same workload.
- Different transactions, such as ad hoc and standardized queries, use the same index concurrently.

Optimistic index locking does not acquire an address lock on the root page of an index partition during normal data manipulation language (DML) operations. If your updates and insertions can cause modifications to the root page of the accessed index partition, optimistic index locking restarts the search and acquires an exclusive table lock, not an address lock.

Two stored procedures are changed by optimistic index locking:

- `sp_chgattribute` enables or disables optimistic index locking; when enabled, setting an exclusive table lock on the table you specify.
- `sp_help` includes a column that displays optimistic index lock.

See *Reference Manual: Procedures*.

## 3.4.1 Using Optimistic Index Locking

Use optimistic index locking when certain conditions are met.

### Context

- There is significant contention on the lock address hash bucket spinlock.
- None of the indexes on this table cause modifications to the root page.
- The number of index levels is high enough to cause no splitting or shrinking of the root page.
- There are large numbers of concurrent accesses to read-only tables on heavily trafficked index pages.
- A database is read-only.

## 3.4.2 Cautions and Issues

Since an exclusive table lock blocks all access by other tasks to the entire table, you must thoroughly understand the user access patterns of your application before enabling optimistic index locking.

The following circumstances require an exclusive table lock:

- Adding a new level to the root page
- Shrinking the root page
- Splitting or shrinking the immediate child of the root page, causing an update on the root page

Do not use optimistic index locking when:

- You have small tables (that are not read-only) with index levels no higher than 3.
- You envision possible modifications to the root page of an index

### **i** Note

An exclusive table lock is an expensive operation, since it blocks access to the entire table. Use extreme caution in setting the optimistic index locking property.

## 4 Lock Tools

`sp_who`, `sp_lock`, and `sp_familylock` report on locks held by users and show processes that are blocked by other transactions.

### 4.1 Information About Blocked Processes

`sp_who` reports on system processes. If a user's command is being blocked by locks held by another task or worker process, the `status` column shows "lock sleep" to indicate that this task or worker process is waiting for an existing lock to be released.

The `blk_spid` or `block_xloid` column shows the process ID of the task or transaction holding the lock or locks.

You can add a user name parameter to get `sp_who` information about a particular SAP ASE user. If you do not provide a user name, `sp_who` reports on all processes in SAP ASE.

For example, consider what happens if you run three sessions in the `pubs2` database: session one deletes the `authors` table, session two selects all the data from the `authors` table, and the third session running `sp_who` against spid 15. In this situation, session two hangs, and session three reports this in the `sp_who` output:

```
sp_who '15'
```

fid	spid	status	loginame	origname	hostname	blk_spid	dbname
	tempdbname	cmd		block_xloid	threadpool		
0	15	recv sleep	sa	sa	PSALDINGXP	0	pubs2
	tempdb	AWAITING COMMAND		0	syb_default_pool		

If you run `sp_who` against spid 16:

```
sp_who '16'
```

fid	spid	status	loginame	origname	hostname	blk_spid	dbname
	tempdbname	cmd		block_xloid	threadpool		
0	16	lock sleep	sa	sa	PSALDINGXP	15	pubs2
	tempdb	SELECT		0	syb_default_pool		

If you run `sp_lock` against spid 15, the `class` column displays the cursor name for locks associated with the current user's cursor and the cursor ID for other users:

fid	spid	loid	locktype	table_id	page
row	dbname	class		context	
0	15	30	Ex_intent	576002052	0

```

0      0      pubs2      Non Cursor Lock
0 15    30      Ex_page-blk    576002052  1008
0      0      pubs2      Non Cursor Lock
0 15    30      Ex_page      576002052  1040
0      0      pubs2      Non Cursor Lock  Ind pg

```

If you run `sp_lock` against `spid 16`, the `class` column displays the cursor name for locks associated with the current user's cursor and the cursor ID for other users:

```

fid  spid  loid  locktype      table_id  page
row  dbname  class  context
----  -
0    16    32    Sh_intent     576002052  0
0    0      pubs2  Non Cursor Lock

```

### Note

The sample output for `sp_lock` and `sp_familylock` in this chapter omits the `class` column to increase readability. The `class` column reports either the names of cursors that hold locks or "Non Cursor Lock."

## 4.2 View Locks with `sp_lock`

Use `sp_lock` to get a report on the locks currently being held on SAP ASE.

The syntax is:

```
sp_lock
```

```

fid  spid  loid  locktype      table_id  page  row  dbname  context
----  -
0    15    30    Ex_intent     208003772  0     0    sales  Fam dur
0    15    30    Ex_page      208003772  2400  0    sales  Fam dur, Ind pg
0    15    30    Ex_page      208003772  2404  0    sales  Fam dur, Ind pg
0    15    30    Ex_page-blk  208003772  946   0    sales  Fam dur
0    30    60    Ex_intent     208003772  0     0    sales  Fam dur
0    30    60    Ex_page      208003772  997   0    sales  Fam dur
0    30    60    Ex_page      208003772  2405  0    sales  Fam dur, Ind pg
0    30    60    Ex_page      208003772  2406  0    sales  Fam dur, Ind pg
0    35    70    Sh_intent     16003088  0     0    sales  Fam dur
0    35    70    Sh_page      16003088  1096  0    sales  Fam dur, Inf key
0    35    70    Sh_page      16003088  3102  0    sales  Fam dur, Range
0    35    70    Sh_page      16003088  3113  0    sales  Fam dur, Range
0    35    70    Sh_page      16003088  3365  0    sales  Fam dur, Range
0    35    70    Sh_page      16003088  3604  0    sales  Fam dur, Range
0    49    98    Sh_intent     464004684  0     0    master  Fam dur
0    50    100   Ex_intent     176003658  0     0    stock  Fam dur
0    50    100   Ex_row       176003658  36773 8     stock  Fam dur
0    50    100   Ex_intent     208003772  0     0    stock  Fam dur
0    50    100   Ex_row       208003772  70483 1     stock  Fam dur
0    50    100   Ex_row       208003772  70483 2     stock  Fam dur
0    50    100   Ex_row       208003772  70483 3     stock  Fam dur
0    50    100   Ex_row       208003772  70483 5     stock  Fam dur
0    50    100   Ex_row       208003772  70483 8     stock  Fam dur
0    50    100   Ex_row       208003772  70483 9     stock  Fam dur
32   13    64    Sh_page      240003886  17264 0     stock
32   16    64    Sh_page      240003886  4376  0     stock

```

32	17	64	Sh_page	240003886	7207	0	stock	
32	18	64	Sh_page	240003886	12766	0	stock	
32	18	64	Sh_page	240003886	12767	0	stock	
32	18	64	Sh_page	240003886	12808	0	stock	
32	19	64	Sh_page	240003886	22367	0	stock	
32	32	64	Sh_intent	16003088	0	0	stock	Fam dur
32	32	64	Sh_intent	48003202	0	0	stock	Fam dur
32	32	64	Sh_intent	80003316	0	0	stock	Fam dur
32	32	64	Sh_intent	112003430	0	0	stock	Fam dur
32	32	64	Sh_intent	176003658	0	0	stock	Fam dur
32	32	64	Sh_intent	208003772	0	0	stock	Fam dur
32	32	64	Sh_intent	240003886	0	0	stock	Fam dur

This example shows the lock status of serial processes and one parallel process:

- `spid 15` holds an exclusive intent lock on a table, one data page lock, and two index page locks. A “blk” suffix indicates that this process is blocking another process that needs to acquire a lock; `spid 15` is blocking another process. As soon as the blocking process completes, the other processes move forward.
- `spid 30` holds an exclusive intent lock on a table, one lock on a data page, and two locks on index pages.
- `spid 35` is performing a range query at isolation level 3. It holds range locks on several pages and an infinity key lock.
- `spid 49` is the task that ran `sp_lock`; it holds a shared intent lock on the `spt_values` table in `master` while it runs.
- `spid 50` holds intent locks on two tables, and several row locks.
- `fid 32` shows several `spids` holding locks: the parent process (`spid 32`) holds shared intent locks on 7 tables, while the worker processes hold shared page locks on one of the tables.

The `lock_type` column indicates not only whether the lock is a shared lock (“Sh” prefix), an exclusive lock (“Ex” prefix), or an “Update” lock, but also whether it is held on a table (“table” or “intent”) or on a “page” or “row.”

A “demand” suffix indicates that the process will acquire an exclusive lock as soon as all current shared locks are released.

The `context` column consists of one or more of the following values:

- “Fam dur” means that the task will hold the lock until the query completes, that is, for the duration of the family of worker processes. Shared intent locks are an example of family duration locks. For a parallel query, the coordinating process always acquires a shared intent table lock that is held for the duration of the parallel query. If the parallel query is part of a transaction, and earlier statements in the transaction performed data modifications, the coordinating process holds family duration locks on all the changed data pages. Worker processes can hold family duration locks when the query operates at isolation level 3.
- “Ind pg” indicates locks on index pages (allpages-locked tables only).
- “Inf key” indicates an infinity key lock, used on data-only-locked tables for some range queries at transaction isolation level 3.
- “Range” indicates a range lock, used for some range queries at transaction isolation level 3.

This example displays locks, including partition locks in the `<partitionid>` column, currently held by SAP ASE.

```
sp_lock
go
fid spid loid locktype          table_id  partitionid page row dbname context
-----
```

```

0 13 26 Ex_intent          420193516          0      0 0 master Non
Cursor Lock
0 13 26 Ex_intent_partition 420193516 452193630      0 0 master Non
Cursor Lock
0 13 26 Ex_page            420193516 452193630 4993 0 master Non
Cursor Lock
0 14 28 Ex_intent          420193516          0      0 0 master Non
Cursor Lock
0 14 28 Ex_intent_partition 420193516 468193687      0 0 master Non
Cursor Lock
0 14 28 Ex_page            420193516 468193687 5001 0 master Non
Cursor Lock
0 16 32 Sh_intent         1006623598          0      0 0 master Non
Cursor Lock

```

To see lock information about a particular login, give the `spid` for the process:

```
sp_lock 30
```

fid	spid	loid	locktype	table_id	page	row	dbname	context
0	30	60	Ex_intent	208003772	0	0	sales	Fam dur
0	30	60	Ex_page	208003772	997	0	sales	Fam dur
0	30	60	Ex_page	208003772	2405	0	sales	Fam dur, Ind
pg								
0	30	60	Ex_page	208003772	2406	0	sales	Fam dur, Ind
pg								

If the `spid` you specify is also the `fid` for a family of processes, `sp_who` prints information for all of the processes.

You can also request information about locks on multiple `spids`:

```
sp_lock 30, 15
```

fid	spid	loid	locktype	table_id	page	row	dbname	context
0	15	30	Ex_page	208003772	2400	0	sales	Fam dur, Ind pg
0	15	30	Ex_page	208003772	2404	0	sales	Fam dur, Ind pg
0	15	30	Ex_page-blk	208003772	946	0	sales	Fam dur
0	30	60	Ex_intent	208003772	0	0	sales	Fam dur
0	30	60	Ex_page	208003772	997	0	sales	Fam dur
0	30	60	Ex_page	208003772	2405	0	sales	Fam dur, Ind pg
0	30	60	Ex_page	208003772	2406	0	sales	Fam dur, Ind pg

## 4.3 View Locks with `sp_familylock`

`sp_familylock` displays the locks held by a family.

This example shows that the coordinating process (`fid 51, spid 51`) holds a shared intent lock on each of four tables and a worker process holds a shared page lock:

```
sp_familylock 51
```

fid	spid	loid	locktype	table_id	page	row	dbname	class	context
-----	------	------	----------	----------	------	-----	--------	-------	---------



51	23	102	Sh_page	208003772	945	0	sales	
51	51	102	Sh_intent	48003202	0	0	sales	Fam dur
51	51	102	Sh_intent	176003658	0	0	sales	Fam dur
51		102	Sh_intent	208003772	0	0	sales	Fam dur

You can also specify two IDs for `sp_familylock`.

You can also view locked partitions in the `sp_familylock` report.

This example displays the partition locks currently held by a family. The class column displays the cursor name for locks associated with a cursor for the current user and the cursor id for other users.

```

sp_familylock
go
Fid spid loid locktype          table_id partitionid page dbname
class          context
-----
25 19 50 Sh_cpartition      672002394          -1 0 userdb Non Cursor
Lock Fam dur
25 19 50 Sh_partition      672002394 688002451 0 userdb Non Cursor
Lock Fam dur
25 20 50 Sh_cpartition      672002394          -1 0 userdb Non Cursor
Lock Fam dur
25 20 50 Sh_intent_partition 672002394 688002451 0 userdb Non Cursor
Lock Fam dur
25 20 50 Sh_partition      672002394 704002508 0 userdb Non Cursor
Lock Fam dur
25 25 50 Sh_intent          672002394          0 0 userdb Non Cursor
Lock Fam dur
(6 rows affected)
(return status = 0)

```

### 4.4 Intrafamily Blocking During Network Buffer Merges

When many worker processes are returning query results, you may see blocking between worker processes.

This example shows five worker processes blocking on the sixth worker process:

```

sp_who 11

```

fid	spid	status	loginame	origname	hostname	blk_spid	dbname
	tempdbname		cmd		block_xloid	threadpool	
11	11	sleeping	diana	diana	olympus	0	sales
	tempdb		SELECT		0	syb_default_pool	
11	16	lock sleep	diana	diana	olympus	18	sales
	tempdb	WORKER	PROCESS		0	syb_default_pool	
11	17	lock sleep	diana	diana	olympus	18	sales
	tempdb	WORKER	PROCESS		0	syb_default_pool	
11	18	send sleep	diana	diana	olympus	0	sales
	tempdb	WORKER	PROCESS		0	syb_default_pool	
11	19	lock sleep	diana	diana	olympus	18	sales
	tempdb	WORKER	PROCESS		0	syb_default_pool	
11	20	lock sleep	diana	diana	olympus	18	sales
	tempdb	WORKER	PROCESS		0	syb_default_pool	
11	21	lock sleep	diana	diana	olympus	18	sales
	tempdb	WORKER	PROCESS		0	syb_default_pool	

Each worker process acquires an exclusive address lock on the network buffer while writing results to it. When the buffer is full, it is sent to the client, and the lock is held until the network write completes.

## 4.5 Monitor Lock Timeouts

SAP ASE includes information for tracking locks.

- The `monLockTimeout` monitoring table provides information about lock requests that are denied because they are blocked for more than the value configured for `lock wait period`. See *Reference Manual: Tables > Monitoring Tables*.
- These configuration parameters configure SAP ASE to collect lock wait timeout information and make it available for the `monLockTimeout` table:
  - `lock timeout pipe active`
  - `lock timeout pipe max messages`

See *Reference Manual: Configuration Parameters*.

# 5 Deadlocks and Concurrency

A deadlock occurs when two user processes each have a lock on a separate data page, index page, partition, row, or table and each wants to acquire a lock on the page, row, partition, or table locked by the other process.

When this happens, the first process is waiting for the second to release the lock, but the second process will not release it until the lock held by the first process is released.

## 5.1 Server-side Versus Application-side Deadlocks

When tasks deadlock in SAP ASE, a deadlock detection mechanism rolls back one of the transactions, and sends messages to the user and to the SAP ASE error log.

Sometimes application-side deadlock situations arise in which a client opens multiple connections, and these client connections wait for locks held by the other connection of the same application. These are not true server-side deadlocks and cannot be detected by SAP ASE deadlock detection mechanisms.

### 5.1.1 Application Deadlock Example

An example showing when deadlocks can occur.

Some developers simulate cursors by using two or more connections from DB-Library™. One connection performs a `select` and the other connection performs updates or deletions on the same tables. This can create application deadlocks. For example:

- Connection A holds a shared lock on a page. As long as there are rows pending from SAP ASE, a shared lock is kept on the current page.
- Connection B requests an exclusive lock on the same pages and then waits.
- The application waits for Connection B to succeed before invoking the logic needed to remove the shared lock. But this never happens.

Since Connection A never requests a lock that is held by Connection B, this is not a server-side deadlock.

## 5.2 Server Task Deadlocks

An example showing a deadlock between two processes.

T19	Event sequence	T20
<pre>begin transaction update savings set balance = balance - 250 where acct_number = 25 update checking set balance = balance + 250 where acct_number = 45 commit transaction</pre>	<p>T19 and T20 start. T19 gets exclusive lock on savings while T20 gets exclusive lock on checking. T19 waits for T20 to release its lock while T20 waits for T19 to release its lock; deadlock occurs.</p>	<pre>begin transaction  update checking set balance = balance - 75 where acct_number = 45  update savings set balance = balance + 75 where acct_number = 25 commit transaction</pre>

If transactions T19 and T20 execute simultaneously, and both transactions acquire exclusive locks with their initial `update` statements, they deadlock, waiting for each other to release their locks, which will not happen.

SAP ASE checks for deadlocks and chooses the user whose transaction has accumulated the least amount of CPU time as the victim.

SAP ASE rolls back that user's transaction, notifies the application program of this action with message number 1205, and allows the other process to move forward.

The example above shows two data modification statements that deadlock; deadlocks can also occur between a process holding and needing shared locks, and one holding and needing exclusive locks.

In a multiuser situation, each application program should check every transaction that modifies data for message 1205 if there is any chance of deadlocking. Message 1205 indicates that a user transaction has been selected as the victim of a deadlock and rolled back. The application program must restart that transaction.

## 5.3 Deadlocks and Parallel Queries

Worker processes can acquire only shared locks, but they can still be involved in deadlocks with processes that acquire exclusive locks.

The locks they hold meet one or more of these conditions:

- A coordinating process holds a table lock as part of a parallel query. The coordinating process could hold exclusive locks on other tables as part of a previous query in a transaction.
- A parallel query is running at transaction isolation level 3 or using `holdlock` and holds locks.
- A parallel query is joining two or more tables while another process is performing a sequence of updates to the same tables within a transaction.

A single worker process can be involved in a deadlock such as those that occur between two serial processes. For example, a worker process that is performing a join between two tables can deadlock with a serial process that is updating the same two tables.

In some cases, deadlocks between serial processes and families involve a level of indirection.

For example, if a task holds an exclusive lock on `tableA` and needs a lock on `tableB`, but a worker process holds a family-duration lock on `tableB`, the task must wait until the transaction that the worker process is involved in completes.

If another worker process in the same family needs a lock on `tableA`, the result is a deadlock.

- The family identified by `fid 8` is doing a parallel query that involves a join of `stock_tbl` and `sales_tbl`, at transaction level 3.
- The serial task identified by `spid 17` (T17) is performing inserts to `stock_tbl` and `sales_tbl` in a transaction.

These are the steps that lead to the deadlock:

- W8 9, a worker process with a `fid` of 8 and a `spid` of 9, holds a shared lock on page 10862 of `stock_tbl`.
- T17 holds an exclusive lock on page 634 of `sales_tbl`. T17 needs an exclusive lock on page 10862, which it cannot acquire until W8 9 releases its shared lock.
- The worker process W8 10 needs a shared lock on page 634, which it cannot acquire until T17 releases its exclusive lock.

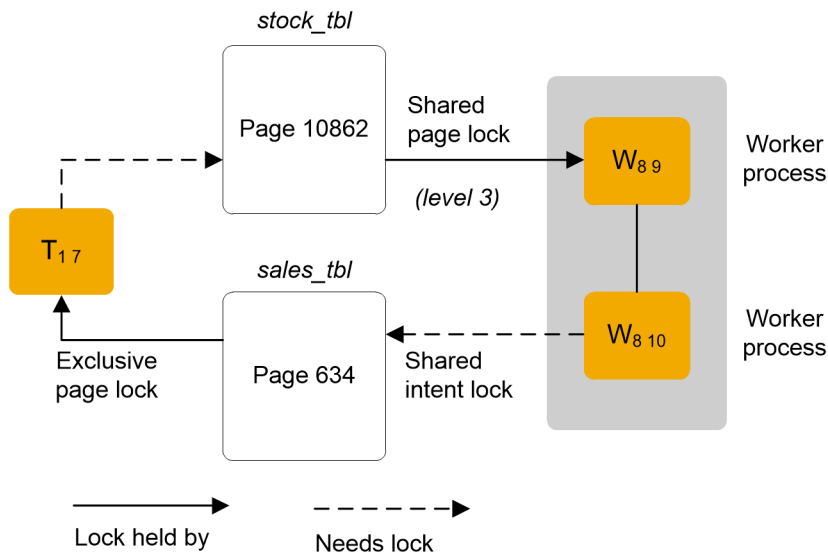

## 5.4 Print Deadlock Information to the Error Log

SAP ASE detects server-side deadlocks to the application and reports them in the server's error log. The error message sent to the application is error 1205.

To get information about the tasks that deadlock, set the `print deadlock information` configuration parameter to 1. This setting sends more detailed deadlock messages to the log and to the terminal session where the server started.

The message sent to the error log, by default, merely identifies that a deadlock occurred. The numbering in the message indicates the number of deadlocks since the last boot of the server.

```
03:00000:00029:1999/03/15 13:16:38.19 server Deadlock Id 11 detected
```

In this output, `fid 0`, `spid 29` started the deadlock detection check, so its `fid` and `spid` values are used as the second and third values in the deadlock message. (The first value, 03, is the engine number.)

However, setting `print deadlock information` to 1 can degrade SAP ASE performance. For this reason, use it only to determine the cause of deadlocks.

Disabling `print deadlock information` (setting it to 0) means that SAP ASE does not send any information about deadlocks to the error log.

The deadlock messages contain detailed information, including:

- The family and server-process IDs of the tasks involved
- The commands and tables involved in deadlocks; if a stored procedure was involved, the procedure name is shown
- The type of locks each task held, and the type of lock each task was trying to acquire
- The server login IDs (`suid` values)

In the following report, `spid 29` is deadlocked with a parallel task, `fid 94`, `spid 38`. The deadlock involves exclusive versus shared lock requests on the `authors` table. `spid 29` is chosen as the deadlock victim:

```
Deadlock Id 11: detected. 1 deadlock chain(s) involved.
Deadlock Id 11: Process (Familyid 94, 38) (suid 62) was executing a SELECT
command at line 1. SQL Text select * from authors where au_id like '172%'
Deadlock Id 11: Process (Familyid 29, 29) (suid 56) was executing a INSERT
command at line 1
SQL Text: insert authors (au_id, au_fname, au_lname) values
('A999999816', 'Bill', 'Dewart')
Deadlock Id 11: Process (Familyid 0, Spid 29) was waiting for a 'exclusive page'
lock on page 1155 of the 'authors' table in database 8 but process (Familyid 94,
Spid 38) already held a 'shared page' lock on it.
Deadlock Id 11: Process (Familyid 94, Spid 38) was waiting for a 'shared page'
lock on page 2336 of the 'authors' table in database 8 but process (Familyid 29,
Spid 29) already held a 'exclusive page' lock on it.
Deadlock Id 11: Process (Familyid 0, 29) was chosen as the victim. End of
deadlock information.
```

## 5.5 Deadlock Avoidance

Deadlocks may occur when many long-running transactions are executed at the same time in the same database. Deadlocks become more common as lock contention increases between transactions, which decreases concurrency.

### 5.5.1 Lock Acquisition on Objects in the Same Order

Well-designed applications can minimize deadlocks by always acquiring locks in the same order. Updates to multiple tables should always be performed in the same order.

In applications with large numbers of tables and transactions that update several tables, establish a locking order that can be shared by all application developers.

### 5.5.2 Delay Deadlock Checking

SAP ASE performs deadlock checking after a minimum period of time for any process waiting for a lock to be released (sleeping). Deadlock checking is time-consuming overhead for applications that wait without a deadlock.

If your applications deadlock infrequently, SAP ASE can delay deadlock checking and reduce the overhead cost. Use the `deadlock checking period` configuration parameter to specify the minimum amount of time (in milliseconds) that a process waits before it initiates a deadlock check.

Valid values are 0 – 2147483. The default value is 500. `deadlock checking period` is a dynamic configuration value, so any change to it takes immediate effect.

If you set the value to 0, SAP ASE initiates deadlock checking when the process begins to wait for a lock. If you set the value to 600, SAP ASE initiates a deadlock check for the waiting process after at least 600 ms. For example:

```
sp_configure "deadlock checking period", 600
```

Setting `deadlock checking period` to a higher value produces longer delays before deadlocks are detected. However, since SAP ASE grants most lock requests before this time elapses, the deadlock checking overhead is avoided for those lock requests.

SAP ASE performs deadlock checking for all processes at fixed intervals, determined by `deadlock checking period`. If SAP ASE performs a deadlock check while a process's deadlock checking is delayed, the process waits until the next interval.

Therefore, a process may wait from the number of milliseconds set by `deadlock checking period` to almost twice that value before deadlock checking is performed. `sp_sysmon` can help you tune deadlock checking behavior.

See *Performance and Tuning Series: Monitoring SAP ASE with sp\_sysmon > Deadlock Detection*.

## 5.6 Identify Tables Where Concurrency is a Problem

`sp_object_stats` prints table-level information about lock contention.

Use it to:

- Report on tables that have the highest contention level
- Report contention on tables in a single database
- Report contention on individual tables

The syntax is:

```
sp_object_stats <interval >[, <top_n >[, <dbname >[, <objname >[,  
<rpt_option> ]]]]
```

To measure lock contention on all tables in all databases, specify only the interval. This example monitors lock contention for 20 minutes, and reports statistics on the 10 tables with the highest levels of contention:

```
sp_object_stats "00:20:00"
```

Additional arguments to `sp_object_stats` are as follows:

- `<top_n>` – allows you to specify the number of tables to be included in the report. The default is 10. To report on the top 20 high-contention tables, for example, use:

```
sp_object_stats "00:20:00", 20
```

- `<dbname>` – prints statistics for the specified database.
- `<objname>` – measures contention for the specified table.
- `<rpt_option >` – specifies the report type:
  - `rpt_locks` reports grants, waits, deadlocks, and wait times for the tables with the highest contention. `rpt_locks` is the default.
  - `rpt_objlist` reports only the names of the objects with the highest level of lock activity.

Here is sample output for `titles`, which uses datapages locking:

```
Object Name: pubtune..titles (dbid=7, objid=208003772,lockscheme=Datapages)
Page Locks      SH_PAGE          UP_PAGE          EX_PAGE
-----
Grants:         94488            4052             4828
Waits:          532              500              776
Deadlocks:      4                0                24
Wait-time:      20603764 ms     14265708 ms     2831556 ms
Contention:     0.56%           10.98%           13.79%
*** Consider altering pubtune..titles to Datarows locking.
```

Table 8: `sp_object_stats` Output

Output row	Value
Grants	The number of times the lock was granted immediately
Waits	The number of times the task needing a lock had to wait



Output row	Value
Deadlocks	The number of deadlocks that occurred
Wait-time	The total number of milliseconds that all tasks spent waiting for a lock
Contention	The percentage of times that a task had to wait or encountered a deadlock

`sp_object_stats` recommends changing the locking scheme when total contention on a table is more than 15 percent, as follows:

- If the table uses allpages locking, it recommends changing to datapages locking.
- If the table uses datapages locking, it recommends changing to datarows locking.

## 5.7 Lock Management Reporting

Output from `sp_sysmon` provides statistics on locking and deadlocks discussed in this chapter.

Use the statistics to determine whether the SAP ASE system is experiencing performance problems due to lock contention.

For more information about `sp_sysmon` and lock statistics, see “Lock management” in *Performance and Tuning Series: Monitoring SAP ASE with sp\_sysmon*.

Use the monitoring tables to pinpoint locking problems. See the *Performance and Tuning Series: Monitoring Tables*.

# 6 Lock Commands

Certain SAP ASE commands affect locking.

## 6.1 Specify the Locking Scheme for a Table

The locking schemes in SAP ASE provide the flexibility to choose the best locking scheme for each table in an application and to adapt the locking scheme for a table if contention or performance requires a change.

The tools for specifying locking schemes are:

- `sp_configure` – specifies a server-wide default locking scheme
- `create table` – specifies the locking scheme for newly created tables
- `alter table` – changes the locking scheme for a table to any other locking scheme
- `select into` – specifies the locking scheme for a table created by selecting results from other tables

### 6.1.1 Specify a Server-Wide Locking Scheme

The `lock scheme` configuration parameter sets the locking scheme to be used for any new table, if the `create table` command does not specify the lock scheme.

To see the current locking scheme, use:

```
sp_configure "lock scheme"
```

Parameter Name	Default	Memory Used	Config Value	Run Value	Unit	Type
lock scheme	allpages	0	datarows	datarows	name	dynamic

The syntax for changing the locking scheme is:

```
sp_configure "lock scheme", 0,  
  {allpages | datapages | datarows}
```

This command sets the default lock scheme for the server to data pages:

```
sp_configure "lock scheme", 0, datapages
```

When you first install SAP ASE, `lock scheme` is set to `allpages`.

## 6.1.2 Specify a Locking Scheme with Create Table

Use `create table` to specify the locking scheme for a new table. The syntax is:

```
create table <table_name> (<column_name_list>
    [lock {datarows | datapages | allpages}]
```

If you do not specify the lock scheme for a table, the default value for the server is used, as determined by the setting of the `lock_scheme` configuration parameter.

This command specifies `datarows` locking for the `new_publishers` table:

```
create table new_publishers
(pub_id      char(4)      not null,
 pub_name   varchar(40)   null,
 city       varchar(20)   null,
 state      char(2)       null)
lock datarows
```

Specifying the locking scheme with `create table` overrides the default server-wide setting.

## 6.1.3 Changing a Locking Scheme with alter table

Use `alter table` to change the locking scheme for a table. The syntax is:

```
alter table <table_name>
    lock {allpages | datapages | datarows}
```

This command changes the locking scheme for the `titles` table to `datarows` locking:

```
alter table titles lock datarows
```

`alter table` supports changing from one locking scheme to any other locking scheme. Changing from `allpages` locking to data-only locking requires SAP ASE to copy the data rows to new pages and re-create any indexes on the table.

Changing the locking scheme requires SAP ASE to perform several steps internally, and requires sufficient space to make the copy of the table and indexes. The time required depends on the size of the table and the number of indexes.

If you are changing from `datapages` locking to `datarows` locking or vice versa, SAP ASE need not copy data pages and rebuild indexes. Switching between data-only locking schemes updates only system tables, and finishes quickly.

### **i** Note

You cannot use data-only locking on tables that have rows that are at, or near, the maximum length of 1962 (including the two bytes for the offset table).

For data-only-locked tables with only fixed-length columns, the maximum user data row size is 1960 bytes (including the 2 bytes for the offset table).

Tables with variable-length columns require 2 additional bytes for each column that is variable-length (this includes columns that allow nulls.)

See “Determining Sizes of Tables and Indexes” in *Performance and Tuning Series: Physical Database Tuning* for information on rows and row overhead.

## 6.1.4 Before and After Changing Locking Schemes

Before you change from allpages locking to data-only locking or vice versa, you should take certain steps.

### Context

- If the table is partitioned, and you have not run `update statistics` since making major data modifications to the table, run `update statistics` on the table that you plan to alter. `alter table...lock` performs better with accurate statistics for partitioned tables. Changing the locking scheme does not affect the distribution of data on partitions; rows in partition 1 are copied to partition 1 in the copy of the table.
- Perform a database dump.
- Set any space management properties that should be applied to the copy of the table or its rebuilt indexes. See “Setting Space Management Properties” in *Performance and Tuning Series: Physical Database Tuning* for information on rows and row overhead.
- Determine if there is enough space. See “Determining the space available for maintenance activities” in *Performance and Tuning Series: Physical Database Tuning*.
- If any of the tables in the database are partitioned and require a parallel sort:
  - Use `sp_dboption` to set the database option `select into/bulkcopy/pllsort` to `true`.
  - Configure for optimum parallel sort performance.

After `alter table` completes:

- Run `dbcc checktable` on the table and `dbcc checkalloc` on the database to ensure database consistency.
- Perform a database dump.

#### **i** Note

After you have changed the locking scheme from allpages locking to data-only locking or vice versa, you cannot use `dump transaction` to back up the transaction log.

You must first perform a full database dump.

## 6.1.5 Expense of Switching To or From Allpages Locking

Switching from allpages locking to data-only locking or vice versa is an expensive operation in terms of I/O cost. Most of the cost comes from the I/O required to copy the tables and re-create the indexes. Some logging is also required.

When moving from allpages to data-only locking or from data-only to allpages locking, `alter table ... lock:`

1. Copies all rows in the table to new data pages, formatting rows according to the new format. If you are changing to data-only locking, any data rows of fewer than 10 bytes are padded to 10 bytes during this step. If you are changing to allpages locking from data-only locking, padding is stripped from rows of fewer than 10 bytes.
2. Drops and re-creates all indexes on the table.
3. Deletes the old set of table pages.
4. Updates the system tables to indicate the new locking scheme.
5. Updates a counter maintained for the table, to cause the recompilation of query plans.

If a clustered index exists on the table, rows are copied in clustered index key order onto the new data pages. If no clustered index exists, the rows are copied in page-chain order for an allpages-locking to data-only-locking conversion.

The entire `alter table...lock` command is performed as a single transaction to ensure recoverability. An exclusive table lock is held on the table for the duration of the transaction.

## 6.1.6 Sort Performance During alter table

During `alter table`, indexes are re-created one at a time. If your system has enough engines, data cache, and I/O throughput to handle simultaneous `create index` operations, you can reduce the overall time required to change locking schemes.

Do this by:

- Dropping the nonclustered indexes
- Altering the locking scheme
- Configuring for best parallel sort performance
- Re-creating two or more nonclustered indexes at once

## 6.1.7 Specify a Locking Scheme with select into

You can specify a locking scheme when you create a new table using `select into`. The syntax is:

```
select [all | distinct] <select_list>
      into [[<database>.]<owner>.]<table_name>
          lock {datarows | datapages | allpages}
from...
```

If you do not specify a locking scheme with `select into`, the new table uses the server-wide default locking scheme, as defined by the configuration parameter `lock scheme`.

This command specifies datarows locking for the table it creates:

```
select title_id, title, price
into bus_titles
lock datarows
from titles
where type = "business"
```

Temporary tables created with the `#tablename` form of naming are single-user tables, so lock contention is not an issue. For temporary tables that can be shared among multiple users, that is, tables created with `tempdb..tablename`, any locking scheme can be used.

## 6.2 Control Isolation Levels

You can set the transaction isolation level used by `select` commands

- For all queries in the session, with the `set transaction isolation level` command
- For an individual query, with the `at isolation` clause
- For specific tables in a query, with the `holdlock`, `noholdlock`, and `shared` keywords

When choosing locking levels in your applications, use the minimum locking level consistent with your business model. The combination of setting the session level while providing control over locking behavior at the query level allows concurrent transactions to achieve required results with the least blocking.

### i Note

If you use transaction isolation level 2 (repeatable reads) on allpages-locked tables, isolation level 3 (serializing reads) is also enforced.

### 6.2.1 Set Isolation Levels for a Session

The SQL standard specifies a default isolation level of 3. To enforce this level, Transact-SQL provides the `set transaction isolation level` command.

For example, you can make level 3 the default isolation level for your session using:

```
set transaction isolation level 3
```

If the session has enforced isolation level 3, you can make the query operate at level 1 using `noholdlock`, as described below.

If you are using the SAP ASE default isolation level of 1, or if you have used the `set transaction isolation level` command to specify level 0 or 2, you can enforce level 3 by using the `holdlock` option to hold shared locks until the end of a transaction.

You can display the current isolation level for a session with the global variable `<@@isolation.>`

## 6.2.2 Syntax for Query-level and Table-level Locking Options

You can specify the `holdlock`, `noholdlock`, and `shared` options for each table in a `select` or `readtext` statement, with the `at isolation` clause applied to the entire query.

```
select <select_list >
from table_name [holdlock | noholdlock] [shared]
    [, table_name [[holdlock | noholdlock] [shared]
{<where/group by/order by/compute clauses>}
[at isolation {
    [read uncommitted | 0] |
    [read committed | 1] |
    [repeatable read | 2]|
    [serializable | 3]]
```

Here is the syntax for the `readtext` command:

```
readtext [[<database>.]<owner>.]<table_name>.<column_name > text_pointer>
offset size
    [holdlock | noholdlock] [readpast]
    [using {bytes | chars | characters}]
[at isolation {
    [read uncommitted | 0] |
    [read committed | 1] |
    [repeatable read | 2]|
    [serializable | 3]]
```

## 6.2.3 holdlock, noholdlock, or shared Usage

You can override a session's locking level by applying the `holdlock`, `noholdlock`, and `shared` options to individual tables in `select` or `readtext` commands:

Level to use	Keyword	Effect
1	<code>noholdlock</code>	Do not hold locks until the end of the transaction; use from level 3 to enforce level 1.
2, 3	<code>holdlock</code>	Hold shared locks until the transaction completes; use from level 1 to enforce level 3.
N/A	<code>shared</code>	Applies shared rather than update locks for <code>select</code> statements in cursors open for update.

These keywords affect locking for the transaction: if you use `holdlock`, all locks are held until the end of the transaction.

If you specify `holdlock` in a query while isolation level 0 is in effect for the session, SAP ASE issues a warning and ignores the `holdlock` clause, not acquiring locks as the query executes.

If you specify `holdlock` and `read uncommitted`, SAP ASE prints an error message, and the query is not executed.

## 6.2.4 at isolation Clause Usage

You can change the isolation level for all tables in the query by using the `at isolation` clause with a `select` or `readtext` command. The options in the `at isolation` clause are:

Level to Use	Option	Effect
0	<code>read uncommitted</code>	Reads uncommitted changes; use from level 1, 2, or 3 queries to perform dirty reads (level 0).
1	<code>read committed</code>	Reads only committed changes; wait for locks to be released; use from level 0 to read only committed changes, but without holding locks.
2	<code>repeatable read</code>	Holds shared locks until the transaction completes; use from level 0 or level 1 queries to enforce level 2.
3	<code>serializable</code>	Holds shared locks until the transaction completes; use from level 1 or level 2 queries to enforce level 3.

Multiversion concurrency control adds these isolation level:

Level to Use	Option	Effect
11	<code>statement snapshot</code>	Scans see a snapshot of committed rows at the start of the statement.  For example, if row <code>r1</code> of table <code>t1</code> has a value of 1 at the start of the statement and this row is updated to a value of 2 while the statement is running, the statement still sees a value of 1. The statement effectively sees the state of the database when the statement starts.
12	<code>transaction snapshot</code>	Scans in the transaction read data that was committed at the time the transaction started. Transactions see a snapshot of the database at the time the transaction started. Any concurrent updates are not seen by the transaction at this isolation level.
13	<code>readonly statement snapshot</code>	Selects see a snapshot of committed rows at the start of the statement (similar to <code>statement snapshot</code> , but only for <code>selects</code> ).  Selects use snapshot isolation and read snapshot when they start. DMLs do not use snapshot isolation, but use traditional isolation levels instead.

In this example, the following statement queries the `titles` table at isolation level 0:

```
select *
from titles
at isolation read uncommitted
```



## 6.2.5 Making Locks More Restrictive

If isolation level 1 is sufficient for most work, but some queries require higher levels of isolation, you can selectively enforce the higher isolation level using clauses in the `select` statement.

### Context

- Use `repeatable read` to enforce level 2
- Use `holdlock` or `at isolation serializable` to enforce level 3

The `holdlock` keyword makes a shared page, row, or table lock more restrictive. `holdlock` applies:

- To shared locks
- To the table or view for which it is specified
- For the duration of the statement or transaction containing the statement

The `at isolation` clause applies to all tables in the `from` clause, and is applied only for the duration of the transaction. The locks are released when the transaction completes.

In a transaction, `holdlock` instructs SAP ASE to hold shared locks until the completion of that transaction instead of releasing the lock as soon as the required table, view, row, or data page is no longer needed. SAP ASE always holds exclusive locks until the end of a transaction.

The use of `holdlock` in the following example ensures that the two queries return consistent results:

```
begin transaction
```

```
select branch, sum(balance)
  from account holdlock
 group by branch
```

```
select sum(balance) from account
```

```
commit transaction
```

The first query acquires a shared table lock on `account` so that no other transaction can update the data before the second query runs. This lock is not released until the transaction including the `holdlock` command completes.

If the session isolation level is 0, and only committed changes must be read from the database, you can use the `at isolation level read committed` clause.

## 6.2.6 Making Locks Less Restrictive

In contrast to `holdlock`, the `noholdlock` keyword prevents SAP ASE from holding any shared locks acquired during the execution of the query, regardless of the transaction isolation level currently in effect.

### Context

`noholdlock` is useful in situations where transactions require a default isolation level of 2 or 3. If any queries in those transactions do not need to hold shared locks until the end of the transaction, you can improve concurrency by specifying `noholdlock` with those queries.

For example, if the transaction isolation level is set to 3, which normally causes a `select` query to hold locks until the end of the transaction, this command releases the locks when the scan moves off the page or row:

```
select balance from account noholdlock
      where acct_number < 100
```

If the session isolation level is 1, 2, or 3, and you want to perform dirty reads, you can use the `at isolation level read uncommitted` clause.

The `shared` keyword instructs SAP ASE to use a shared lock (instead of an update lock) on a specified table or view in a cursor.

### Related Information

[shared Keyword Usage \[page 84\]](#)

## 6.3 Readpast Locking

Readpast locking allows `select` and `readtext` queries to skip all rows or pages locked with incompatible locks. The queries do not block, terminate, or return error or advisory messages to the user. Readpast locking is largely designed to be used in queue-processing applications.

In general, these applications allow queries to return the first unlocked row that meets query qualifications. An example might be an application tracking calls for service: the query needs to find the row with the earliest timestamp that is not locked by another repair representative.

For more information on `readpast` locking, see “Locking Commands and Options” in the *Transact-SQL User’s Guide*.

## 6.4 Cursors and Locking

Cursor locking methods are similar to the other locking methods in SAP ASE. For cursors declared as `read only` or declared without the `for update` clause, SAP ASE uses a shared page lock on the data page that includes the current cursor position.

When additional rows for the cursor are fetched, SAP ASE acquires a lock on the next page, the cursor position is moved to that page, and the previous page lock is released (unless you are operating at isolation level 3).

For cursors declared with `for update`, SAP ASE uses update page locks by default when scanning tables or views referenced with the `for update` clause of the cursor. For data-only-locked tables, SAP ASE may use a table scan to avoid the Halloween problem. For more information see “Optimization for Cursors” in *Performance and Tuning Series: Query Processing and Abstract Plans*.

If the `for update` list is empty, all tables and views referenced in the `from` clause of the `select` statement receive update locks. An update lock is a special type of read lock that indicates that the reader may modify the data soon. An update lock allows other shared locks on the page, but does not allow other update or exclusive locks.

If a row is updated or deleted through a cursor, the data modification transaction acquires an exclusive lock. Any exclusive locks acquired by updates through a cursor in a transaction are held until the end of that transaction and are not affected by closing the cursor. This is also true of shared or update locks for cursors that use the `holdlock` keyword or isolation level 3.

Locking behavior for cursors at each isolation level is as follows:

- At level 0, SAP ASE uses no locks on any base table page that contains a row representing a current cursor position. Cursors acquire no read locks for their scans, so they do not block other applications from accessing the same data.  
However, cursors operating at this isolation level are not updatable, and they require a unique index on the base table to ensure accuracy.
- At level 1, SAP ASE uses shared or update locks on base table or leaf-level index pages that contain a row representing a current cursor position.  
The page remains locked until the current cursor position moves off the page as a result of `fetch` statements.
- At level 2 or 3, SAP ASE uses shared or update locks on any base table or leaf-level index pages that have been read in a transaction through the cursor.  
SAP ASE holds the locks until the transaction ends; it does not release the locks when the data page is no longer needed or when the cursor is closed.

If you do not set the `close on endtran` or `chained` options, a cursor remains open past the end of the transaction, and its current page locks remain in effect. It may also continue to acquire locks as it fetches additional rows.

## 6.4.1 shared Keyword Usage

When declaring an updatable cursor using the `for update` clause, you can use shared page locks (instead of update page locks) in the `declare cursor` statement:

```
declare <cursor_name> cursor
  for select <select_list>
  from {<table_name> | <view_name>} shared
  for update [of <column_name_list>]
```

This allows other users to obtain an update lock on the table or an underlying table of the view.

You can use the `holdlock` keyword with `shared` after each table or view name. `holdlock` must precede `shared` in the `select` statement. For example:

```
declare authors_crsr cursor
for select au_id, au_lname, au_fname
  from authors holdlock shared
  where state != 'CA'
  for update of au_lname, au_fname
```

These are the effects of specifying the `holdlock` or `shared` options when defining an updatable cursor:

- If you do not specify either option, the cursor holds an update lock on the row or on the page containing the current row.  
Other users cannot update, through a cursor or otherwise, the row at the cursor position (for datarows-locked tables) or any row on this page (for allpages and datapages-locked tables).  
Other users can declare a cursor on the same tables you use for your cursor, and can read data, but they cannot get an update or exclusive lock on your current row or page.
- If you specify the `shared` option, the cursor holds a shared lock on the current row or on the page containing the currently fetched row.  
Other users cannot update, through a cursor or otherwise, the current row, or the rows on this page. They can, however, read the row or rows on the page.
- If you specify the `holdlock` option, you hold update locks on all the rows or pages that have been fetched (if transactions are not being used) or only the pages fetched since the last commit or rollback (if in a transaction).  
Other users cannot update, through a cursor or otherwise, currently fetched rows or pages.  
Other users can declare a cursor on the same tables you use for your cursor, but they cannot get an update lock on currently fetched rows or pages.
- If you specify both options, the cursor holds shared locks on all the rows or pages fetched (if not using transactions) or on the rows or pages fetched since the last commit or rollback.  
Other users cannot update, through a cursor or otherwise, currently fetched rows or pages.

## 6.5 lock table

Explicitly locks a table within a transaction.

In transactions, you can use the `lock table` command to:

- To immediately lock the entire table, rather than waiting for lock promotion to take effect.

- When the query or transactions uses multiple scans, and none of the scans locks a sufficient number of pages or rows to trigger lock promotion, but the total number of locks is very large.
- When large tables, especially those using datarows locking, need to be accessed at transaction level 2 or 3, and lock promotion is likely to be blocked by other tasks. Using `lock table` can prevent running out of locks.

The table locks are released at the end of the transaction.

`lock table` allows you to specify a wait period. If the table lock cannot be granted<sup>4</sup> within the wait period, an error message is printed, but the transaction is not rolled back.

## 6.6 Lock Timeouts

Specify the amount of time that a task waits for a lock

You can specify:

- At the server level, with the `lock wait period` configuration parameter
- For a session or in a stored procedure, with the `set lock wait` command
- For a `lock table` command

See the *Transact-SQL Users Guide* for more information on these commands.

Except for `lock table`, a task that attempts to acquire a lock and fails to acquire it within the time period returns an error message and the transaction is rolled back.

Using lock timeouts can be useful for removing tasks that acquire some locks, and then wait for long periods of time blocking other users. However, since transactions are rolled back, and users may simply resubmit their queries, timing out a transaction means that the work needs to be repeated.

Use `sp_sysmon` to monitor the number of tasks that exceed the time limit while waiting for a lock.

See “Lock time-out information” in *Performance and Tuning Series: Monitoring SAP ASE with sp\_sysmon*.

## 6.7 Preventing Blocking Row Counts

SAP ASE enables you to prevent row counts from blocking.

Row counts can block on objects that already have an EX\_TAB lock and time out while waiting for an SH\_INT lock. Prevent blocking row counts with the following options:

- `row_count ... noblock` – retrieves the count values from in-memory descriptors achieving non-blocking behavior. The syntax is:

```
row_count(<dbid>, <object_id> [,ptnid] [,"noblock"])
```

- `set non_blocking_builtins` – configures the current session to use the nonblocking behavior. The syntax is:

```
set non_blocking_builtins {on | off}
```

This example determines the row count for database Id 4 and object Id 1586101660:

```
select row_count(4, 1586101660, "noblock")
-----
                41000
```

This specifies non-blocking behavior for `row_count`, for the session:

```
set non_blocking_builtins on
```

# 7 Indexes

SAP ASE stores indexes and uses them to speed data retrieval for select, update, delete, and insert operations.

Indexes are the most important physical design element in improving database performance:

- Indexes help to avoid table scans. A few index pages and data pages can satisfy many queries without requiring reads on hundreds of data pages.
- For some queries, data can be retrieved from a nonclustered index without accessing data rows.
- Clustered indexes can randomize data inserts, avoiding insert hot spots on the last page of a table.
- Indexes can help to avoid sorts, if the index order matches the order of the columns in an `order by` clause.
- For most partitioned tables, you can create global indexes with one index tree to cover the whole table, or you can create local indexes with multiple index trees, each of which covers one partition of the table.

In addition to their performance benefits, indexes can enforce the uniqueness of data.

Indexes are database objects created on a table to speed direct access to specific data rows. Indexes store the values of the keys named when the index was created and logical pointers to the data pages or to other index pages.

Although indexes speed data retrieval, they can slow down data modifications, since most changes to the data require index updates. Optimal indexing demands an understanding of:

- The behavior of queries that access unindexed heap tables, tables with clustered indexes, and tables with nonclustered indexes
- The mix of queries that run on your server
- The relative benefits of local and global indexes on partitioned tables
- The SAP ASE optimizer

## 7.1 Types of Indexes

SAP ASE provides two general types of indexes that can be created at the table or at the partition level.

- Clustered indexes, where the data is physically stored in the order of the keys on the index:
  - For allpages-locked tables, rows are stored in key order on pages, and pages are linked in key order.
  - For data-only-locked tables, indexes are used to direct the storage of data on rows and pages, but strict key ordering is not maintained.
- Nonclustered indexes, where the storage order of data in the table is not related to index keys

You can create only one clustered index on a table or partition because there is only one possible physical ordering of the data rows. You can create up to 249 nonclustered indexes per table.

A table that has no clustered index is called a heap. The rows in the table are in no particular order, and all new rows are added to the end of the table. Chapter 2, "Data Storage," in Performance and Tuning Series: Physical Database Tuning discusses heaps and SQL operations on heaps.

Function-based indexes are a type of nonclustered index which use one or more expressions as the index key. See the *Transact-SQL Users Guide* for more on creating function-based indexes.

## Related Information

[Indexes and Partitions \[page 98\]](#)

[Indexing for Concurrency Control \[page 116\]](#)

### 7.1.1 Index Pages

Index entries are stored as rows on index pages in a format similar to that of data rows on data pages. Index entries store key values and pointers to lower levels of the index, to the data pages, or to individual data rows.

SAP ASE uses B-tree indexing, so each node in the index structure can have multiple children.

Index entries are usually much smaller than a data row in a data page, and index pages are typically much more densely populated than data pages. If a data row has 200 bytes (including row overhead), there are 10 rows per page on a 2K server. However, an index on a 15-byte field has about 100 rows per index page on a 2K server (the pointers require 4 – 9 bytes per row, depending on the type of index and the index level).

Indexes can have multiple levels:

- Root level
- Leaf level
- Intermediate level

#### 7.1.1.1 Root Level

The root level is the highest level of the index. There is only one root page.

If an allpages-locked table is very small, so that the entire index fits on a single page, there are no intermediate or leaf levels, and the root page stores pointers to the data pages.

Data-only-locked tables always have a leaf level between the root page and the data pages.

For larger tables, the root page stores pointers to the intermediate level index pages or to leaf-level pages.

#### 7.1.1.2 Leaf Level

The lowest level of the index is the leaf level.

At the leaf level, an index contains a key value for each row in the table, and the rows are stored in sorted order by the index key:



- For clustered indexes on allpages-locked tables, the leaf level is the data. No other level of the index contains one index row for each data row.
- For nonclustered indexes and clustered indexes on data-only-locked tables, the leaf level contains the index key value for each row, a pointer to the page, and the row containing the specific key value. The leaf level is the level just above the data; it contains one index row for each data row. Index rows on the index page are stored in key value order.

### 7.1.1.3 Intermediate Level

All levels between the root and leaf levels are intermediate levels. An index on a large table or an index using long keys may have many intermediate levels. Indexes on a very small table may not have an intermediate level; the root pages point directly to the leaf level.

## 7.1.2 Index Size

Index size limits for APL and DOL tables.

Page Size	User-visible Index Row-size Limit	Internal Index Row-size Limit
2K (2048 bytes)	600	650
4K (4096 bytes)	1250	1310
8K (8192 bytes)	2600	2670
16K (16384 bytes)	5300	5400

You can create tables with columns wider than the limit for the index key; however, these columns become nonindexable. For example, if you perform the following on a 2K page server, then try to create an index on c3, the command fails and SAP ASE issues an error message because column c3 is larger than the index row-size limit (600 bytes).

```
create table t1 (c1 intc2 intc3 char(700))
```

You can still create statistics for a nonindexable column, or include it in search results. Also, if you include the column in a `where` clause, it is evaluated during optimization.

An index row size that is too large can result in frequent index page splits. Page splits can make the index level grow linearly with the number of rows in the table, making the index useless because the index traverse becomes expensive. SAP ASE limits the index size to, at most, approximately one third of server's page size, so that each index page contains at least three index rows.

## 7.1.3 Using Latch-Free Indexes

SAP ASE allows you to create indexes that do not require latches during traversals or scans, which can reduce contention. You can use latch-free indexes only on data-only locked user tables.

### i Note

This feature is part of the MemScale option. See *SAP ASE Options* in the Installation Guide for your platform. Before using this feature, set the `enable mem scale` configuration parameter. Next, set the `enable LFB index` configuration parameter. See *System Administration Guide, Volume 1*

Scans or traversals on latched indexes use the buffer manager to retrieve an index page, which can result in contention when opposing threads try to acquire the same latch. Latch-free indexes use in-memory mapping tables instead of buffer managers to retrieve an index page. Mapping tables are database specific and are created when DML occurs on latch-free indexes in this database for the first time. Mapping tables are an array with a single field, which contains the memory address of an index page. A non-null field indicates that SAP ASE can use this memory address to locate changes for this page. A null field indicates that this page is not cached in a mapping table (maybe it is already in memory, but not cached in a mapping table).

Latch-free indexes use delta updates (that is, changes since the last commit) to prepend changes to the index page instead of changing the page directly. The mapping table that corresponds to the change points to the latest delta update to ensure that the page is physically unchanged when some sessions are performing traversal on that page. That is, a page in memory looks like chained delta structures and ends with the original buffer of the page. When there are 16 delta changes to one index page, the server consolidates the changes to a page in memory and updates the corresponding mapping table.

Use `create table` to create a table that allows latch-free indexes. All subsequent indexes created on this table will use the latch-free policy. Use `create index` to create the latch-free index.

The syntax is:

```
create table <table_name>
...
with latch_free_index {on | off}
```

For example:

```
create table big_table (
    storid          char(4)          not null
    , ord_num       varchar(20)      not null
    , order_date    datetime         not null
)
with latch_free_index = on
```

Create the latch-free index:

```
create index idx_char on big_table(storid)
```

Use `alter table` to change the latch-free index policy of an existing table. Use `alter index` to alter the latch-free policy of an existing index. Enabling or disabling the latch-free policy of a table does not affect the policy of the existing indexes; it only affects the policy of subsequent indexes.

The syntax is:

```
alter table <table_name>
```

```
...
set latch_free_index = {on | off}
```

```
alter index <table_name>.<index_name>
...
set latch_free_index = {on | off}
```

Use `create database` to create a database that enables latch-free-index by default. All tables created in this database use the latch-free policy.

The syntax is:

```
create database <database_name>
...
with latch_free_index {on | off}
```

Use `alter database` to change the latch-free index policy of a database. Enabling or disabling the latch-free policy of a database does not affect the policy of the existing tables and indexes; it only affects the policy of subsequent tables. Use the `for all tables` option to change the latch-free policy of all existing tables and indexes.

The syntax is:

```
alter database <database_name>
...
set latch_free_index = {on | off} [for all tables]
```

See *Reference Manual: Commands*.

Use `monLocks` monitoring table to make sure that the number of latches is reduced while a latch-free index is enabled.

Monitor latch-free indexes using `monLatchFreeIndex`.

See *Reference Manual: Tables*.

## 7.1.4 Hash-Cache BTree Indexes

Hash-cached Btree indexes consist of a lockless hash table and a traditional Btree index.

Hash caches are primarily used for hot rows (that is, portions of a table, usually small, that are transactionally active and memory-resident) from in-memory row storage. The hash code is calculated based on index keys of frequently accessed data rows and is saved in the hash node.

When it is next accessed after it is cached into the hash table, the data row ID is received directly from hash table, reducing the path to the RID of the qualified data row from the traditional BTree index and improving performance. Because lockless hash tables are to cache the information of qualified rows, the lock is not taken while traversing or changing hash tables, preventing query tasks from blocking on tasks that are changing a hash table. As a result, the time spent on index query is reduced, improving the index layer query performance.

See the *In-Memory Database Users Guide* for information about in-memory row storage.

Use the `create index` command to create hash-cache BTree indexes. The syntax is:

```
create index <index_name>
```

```
. . .  
with [index_hash_caching = {on [, bucket_count = <number> ] on | off | default}}
```

Use the `alter index` to change existing indexes to use hash caches. The syntax is:

```
alter index <index_name>  
. . .  
set [index_hash_caching = {on [, bucket_count = <number> ] on | off | default}}
```

See the *Reference Manual: Commands*.

It is important that the bucket count be set properly. If the bucket count is set too high, more memory is used; if it is set too low, more hash collisions occur, and, as a result, many hash nodes are mapped to the same hash bucket, causing the hash chain length to grow. The longer the hash chain, the slower the speed of equality lookups in the hash chain. If data is not regularly inserted, the bucket count could be up to twice the number of distinct data rows covered by the index. Alternatively, you can set the bucket count up to twice the number of distinct data rows covered by the index as starting value, and tune it based on the statistics collected in `monHCBPartitionActivity`.

Use the `dbcc hcb` parameter to display hash-cached BTree information (for example, all hash nodes in a given hash table, or those in a specified hash bucket). See the *Reference Manual: Commands* for `dbcc` syntax and usage information.

Hash-cached BTree indexes differ from traditional BTree indexes in that:

- Hash caching is used only for equality comparisons that use the `=` or `in` operators. Hash caches are not used for comparison operators that find range values, such as `<` and `>`.
- The optimizer cannot use hash caching to expedite `order by` operations.

A hash table is not initially allocated when you first create a hash-cache BTree index, and no memory is consumed at that time. When you run the first point query using this index, it searches the BTree index for the qualified data row. The query then allocates the hash bucket on demand, creates a hash node, fills it with the hash code and the data row RID, and inserts it into the hash bucket.

The `HCB GC` background garbage collection task reclaims unused memory from the deleted hash node. The server creates the `HCB GC` garbage collection tasks for databases that contain indexes with hash caching enabled. By default, one task is created for each database. However, if the server requires additional memory clean-up, and current garbage collection tasks cannot keep up, you can add additional garbage collection tasks by increasing the `number of hcb gc tasks per db` configuration parameter. For example, this configures the server to have 10 `HCB GC` tasks per database:

```
sp_configure "number of hcb gc tasks per db", 10
```

DML interactions with hash-cache BTree indexes:

- `insert` – inserting a data row into a table with a hash-cache BTree index also inserts a corresponding index row into the disk-based BTree index. `insert` does not create new nodes in hash table.
- `delete` – deleting a data row from a table with a hash-cache BTree index also logically deletes the index row of the disk-based BTree index. The hash node that points to this row is removed from the hash table and is added to a GC queue. However, the memory from this node is not freed at this time because there may be active scanners working on it. `HCB GC` tasks free this memory at a later time.
- `update` – updating a data row for a table with a hash-cache BTree also updates the index using a `delete` then an `insert`. If the index row is already cached in the hash table, the entry pointing to the old data row

image is deleted first. The new data row image is not added to the hash-cache BTree at this time, but is added by the next point query.

In this example of a table named `country`, which includes the `country_code` and `country_name` columns, and uses an index with hash caching enabled:

<code>country_code</code>	<code>country_name</code>
UK	United Kingdom
US	United States
ITAL	Italy

A hash-cache BTree is created on the `country_code` column, and the hash function is the first character's byte value. A query like `select * from contry where country_code = 'US'` first calculates the hash code for `us` to determine the corresponding bucket index, and follows the link to find the row.

### 7.1.4.1 Tuning the Hash-Cached B-tree Indexes

Generally, queries using hash-cached B-tree indexes should benefit from a reduced B-tree codepath. There are a number of ways to determine when queries cannot use hash-cached B-tree indexes.

The `monHCBPartitionActivity` monitoring table provides information about the total number of hash-cached B-tree indexes scans performed on an index, and how many of them were successful. For example:

```
select HDBName, ObjectName, PartitionName, HashCacheScans, HashCacheHits,
HashCacheSkips, NScanFailedNoHashTable, NScanFailedNoHashNode,
NScanFailedNotQualified
from master..monHCBPartitionActivity
HDBName          ObjectName
PartitionName     HashCacheScans     HashCacheHits
HashCacheSkips    NScanFailedNoHashTable NScanFailedNoHashNode
NScanFailedNotQualified
-----
-----
-----
tpcc
w_clu_592002109      w_clu          20839897
20839902             1              0
0                   0
tpcc
d_clu_624002223      d_clu          21800252
21800243             0              0
0                   11
tpcc
i_clu_816002907      i_clu          105868858
105758507            0              0
110355              0
tpcc
s_clu_848003021      s_clu          106784045
98288519             0              0
7518574             960390
tpcc
o_clu_752002679      o_clu          9623634
5                   0              0
9609497             0
```



```

1          6          0          106784045
98288519          0          1069550832
0          7518574          960390
0          7535112          0 tpcc
s_clu          s_clu_848003021
4 752002679 2 752002679
16777216          8101774          8
1          6          0
9623634          5          0
576896024          0          9609497
0          0          9623619          0
tpcc          o_clu
o_clu_752002679
4 656002337 2 656002337
16777216          4477038          6
1          5          0          32459225
30060740          0          342544424
0          2396220          53
0          2398426          0 tpcc
c_clu          c_clu_656002337

```

This output provides:

- The maximum hash chain length seen in a hash table (`MaxChainLength`). The longer the length, the poorer the scan performance.
- Total amount of memory used by an in-memory hash table, indicated by `MemoryUsed`.

The `monBucketPool` monitoring table provides information about the memory pool used by in-memory hash table with a hash-cached B-tree (for example, bucketpool size, number of buckets, bucketpool overheads, and so on). Query `monBucketPool` using a `BucketPoolName` of `HCB Index Memory Pool` to view the information:

```
select * from monBucketPool where BucketPoolName like "HCB Index Memory Pool"
```

Check the bucket pool usage by querying `monBucketPool` using the steps described the "*In-Memory Database Users Guide > Performance and Tuning the IMRS.*"

If the server is not utilizing the hash-cache B-tree efficiently due to insufficient memory, allocate additional memory to the hash-cache B-tree memory pool with the `HCB index memor pool size` configuration parameter. For example:

```
sp_configure "HCB index memory pool size", 1000000
```

If the configured bucket count is too small, more hash nodes are mapped to the same bucket, resulting in long hash chains, which take a long time to traverse. `monHCBPartitionActivity` provides information about the size of the hash-cached, hash table for each index, the maximum and average chain lengths, and so on:

```

select DBID, ObjectID, IndexID, PartitionID, TotalBuckets, UsedBuckets,
MaxChainLength, AvgChainLength, MaxScanLength, AvgScanLength, MemoryUsed,
NHashNodesInserted, NHashNodesDeleted
from master..monHCBPartitionActivity
  DBID      ObjectID      IndexID      PartitionID  TotalBuckets
UsedBuckets      MaxChainLength      AvgChainLength
MaxScanLength      AvgScanLength      MemoryUsed
NHashNodesInserted      NHashNodesDeleted
-----
-----
-----
-----
-----
131072          4 592002109          2 592002109
          240          1

```

1		0		0		
1058280			0		0	
	4	624002223		2	624002223	
131072		2379			2	
1		1			0	
1144680			0			0
	4	816002907		2	816002907	
262144		82798			5	
1		4			0	6079712
4414		0				
	4	848003021		2	848003021	
67108864		12079732			7	
1		6			0	1069550832
7535112			0			
	4	752002679		2	752002679	
16777216		8101774			8	
1		6			0	576896024
9623619			0			
	4	656002337		2	656002337	
16777216		4477038			6	
1		5			0	342544424
2398426			0			

If you see large values in the `NHashNodesAllocOOM` or `NHashBucketsAllocOOM` columns of `monHCBPartitionActivity`, consider increasing the size of the hash-cache B-tree memory pool.

These columns from the `monHCBPartitionActivity` monitoring table give a general idea about maximum and average chain length:

- `MaxChainLength`
- `AvgChainLength`
- `MaxScanLength`
- `AvgScanLength`

These columns from the `monHCBPartitionActivity` monitoring table indicated the maximum and average hash nodes traversed by scanners:

- `MaxScanLength`
- `AvgScanLength`

A large value (close to 64) indicates that most scanners must traverse numerous hash nodes before stopping. Consider using `alter index` to increase the bucket count.

Occasionally, hash nodes may not be well distributed in all hash buckets, with some hash chains being very long and others very short. If the `NScanFailedMaxScanLength` column has a large value, consider using `alter index` to increase the configured bucket count.

## 7.1.4.2 Determining if Auto Tuning Thresholds Are Adequate

Generally, HCB auto tuning relies on a series of collected metrics to evaluate whether hash caching is used efficiently, and disables it for those indexes if it is not.

These are the important metrics used during the evaluation:

- Point query rate – the default threshold is 30%. Set this threshold with the `point query rate threshold` configuration parameter.



- Hash table hit rate – the default threshold is 60%. Set this threshold with the `hash table hit rate threshold` configuration parameter.

If either of these rates are lower than their threshold, hash-cache index auto tuning task attempts to disable index hash caching for this index. The higher you set the thresholds, the more rigorous the server selects for hash-cache indexes that are suitable.

`monHCBTuneActivity` provides some rough information about the auto tuning threshold rates. For example

```
select * from monHCBTuningActivity
DBName      ObjectName      PartitionName      CurPQueryRate      LastPQueryRate
AvgPQueryRate PQueryRateThreshold CurHashScanHitRate      LastHashScanHitRate
AvgHashScanHitRate      HashScanHitRateThreshold
-----
-----
tpcc      w_clu      w_clu_592002109      100
100      100      30      100
100      99      60
tpcc      d_clu      d_clu_624002223      100
100      100      30      100
100      99      60
tpcc      i_clu      i_clu_816002907      100
100      100      30      99
99
tpcc      s_clu      s_clu_848003021      100
100      100      30      93
92      71
tpcc      o_clu      o_clu_752002679      100
100      100      30      0
0
tpcc      c_clu      c_clu_656002337      100
100      100      30      95
94      78      60
```

Use the average, last, and current rates as a reference to modify the thresholds. These columns give a rough idea if the point query rate is too small

- `CurPQueryRate`
- `LastPQueryRate`
- `AvgPQueryRate`
- `PQueryRateThreshold`

These columns help identify if the hash table hit rate is adequate:

- `CurHashScanHitRate`
- `LastHashScanHitRate`
- `AvgHashScanHitRate`
- `HashScanHitRateThreshold`

## 7.2 Indexes and Partitions

Partitioned tables include additional indexing options. Indexes on partitioned tables can be either global (one index tree covering all the data in the table) or local (multiple index trees, each of which covers only the data within its corresponding data partition).

### 7.2.1 Local Indexes on Partitioned Tables

Both clustered and nonclustered local indexes are supported on all types of partitioned tables. Each index partition spans a single data partition; that is, the index partition is “equipartitioned” with the table. On range-, list-, and hash-partitioned tables, clustered indexes are always local indexes.

When you create a local index, you actually create separate index trees for each partition in the table. However, SAP ASE does not support partial indexes, so you cannot selectively create local indexes for certain partitions.

### 7.2.2 Global Indexes on Partitioned Tables

Global indexes on partitioned tables span all the partitions in the table; that is, a single index tree covers all the data in the table, regardless of partitions.

Global indexes on range-, list-, or hash-partitioned tables may only be nonclustered, since clustered index ordering conflicts with partition ordering of the data.

Global clustered indexes are allowed on round-robin partitioned tables.

### 7.2.3 Local versus Global Indexes

Differences between local and global indexes.

- Local indexes can increase concurrency through multiple index access points, which reduces root-page contention.
- You can place local nonclustered index subtrees (index partitions) on separate segments to increase I/O parallelism.
- You can run `reorg rebuild` on a per-partition basis, reorganizing the local index sub-tree while minimizing the impact on other operations.
- Global nonclustered indexes are better for covered scans than local indexes, especially for queries that need to fetch rows across partitions.

## 7.2.4 Unsupported Partition Index Types

Global partitioned indexes are not supported, meaning that global indexes that cover all the data in the table are not themselves partitioned. Global clustered indexes are supported only on round-robin partitioned tables.

## 7.3 Creating Partial Indexes

Partial indexes produce a subset of rows, allowing the index to remain small and extremely selective, even though the table may be large. Partial indexes are also known as filtered indexes.

### Context

In SAP ASE 15.7 SP130 and later, partial indexes are based on partitioned tables, and the condition that creates the partial index is the same as the condition that defines the data partition.

Versions of the server earlier than SP130 run `create local index` in serial if the table has more than 254 partitions. However, you can configure SP130 and later at the session level to create local indexes in parallel (typically used to create partial indexes for different data partitions in different sessions). Create partial indexes for different data partitions concurrently, using a number of sessions that is based on the available system resources like the number of engines, size of the data cache, and so on.

After you create all index partitions, the indexes become regular local indexes.

For example, if table `t_big` has 300 data partitions named `dp1, dp2, dp3, ..., dp300`, and the system includes 3 engines available for creating indexes, you can use 3 sessions to create partial indexes:

- Session 1 – create partial index for `dp1, dp4, ..., dp298`
- Session 2 – create partial index for `dp2, dp5, ..., dp299`
- Session 3 – create partial index for `dp3, dp6, ..., dp300`

Use `sp_helpindex` to display whether an index is a partial or a local index.

Use partial indexes when any of the following are true:

- The table is located on a nonproxy, user database.
- The table is user-partitioned, and is not a proxy or deferred table.
- The index is a nonclustered local index, and is not a functional replication index.
- The index was not created with `online index`.

For example, if you partition a table according to phone number area codes, each partial index would comprise one of the area codes.

Use the `create index` command to create partial indexes. The syntax is

```
create [unique] [nonclustered]
    index <index_name> on [[<database>.]<owner>.]<table_name>
    .
    .
    | partial index [<index_partition_name>]
    |               [on <segment_name>]
```

```
for <data_partition_name>
```

## Procedure

For example, if your partitioned tables includes millions of rows of real estate data partitioned according to zip code, but you are only interested in houses in the 94121 area code, you could create a partial index on the houses that are in this zip code, significantly reducing the amount of data SAP ASE needs to index:

```
create index address_idx on address_tab(  
zip_code, name, address_str) partial index 94121_index for 94121_partition
```

## 7.4 Clustered Indexes on Allpages-locked Tables

In clustered indexes on allpages-locked tables, leaf-level pages are also the data pages, and all rows are kept in physical order by the keys.

Physical ordering means that:

- All entries on a data page are in index key order.
- By following the “next page” pointers on the data pages, SAP ASE reads the entire table in index key order.

On the root and intermediate pages, each entry points to a page on the next level.

### 7.4.1 Clustered Indexes and select Operations

SAP ASE uses `syspartitions` to find the root page to select a particular column (for example, a last name) using a clustered index (in versions earlier than 15.0, SAP ASE used `sysindexes`).

SAP ASE examines the values on the root page and then follows page pointers, performing a binary search on each page it accesses as it traverses the index.

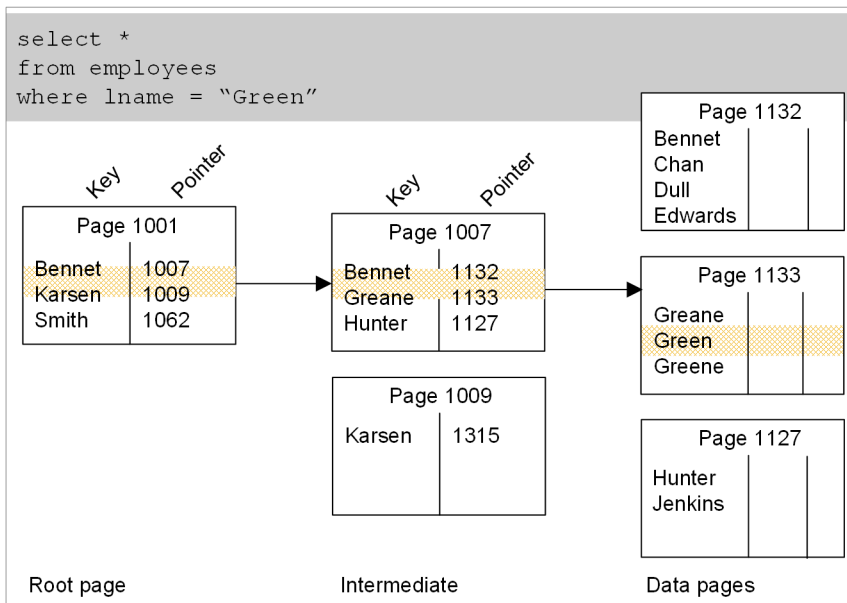

In the root level page, "Green" is greater than "Bennet," but less than Karsen, so the pointer for "Bennet" is followed to page 1007. On page 1007, "Green" is greater than "Greane," but less than "Hunter," so the pointer to page 1133 is followed to the data page, where the row is located and returned to the user.

This retrieval using the clustered index requires one read for each of the:

- Root level of the index
- Intermediate level
- Data page

These reads may come either from cache or from disk. On tables that are frequently used, the higher levels of the indexes are often found in cache, with lower levels and data pages being read from disk.

### 7.4.1.1 Relationship Between Physical and Logical Reads

If SAP ASE reads a page from disk, it is counted as a physical and a logical read. The cost of logical I/O is always greater than or equal to physical I/O.

Logical I/O always reports 2K data pages. Physical reads and writes are reported in buffer-sized units. Multiple pages that are read in a single I/O operation are treated as a unit: they are read, written, and moved through the cache as a single buffer.

### 7.4.2 Clustered Indexes and insert Operations

When you insert a row into an allpages-locked table with a clustered index, the data row must be placed in physical order according to the key value on the table.

Other rows on the data page move down on the page, as needed, to make room for the new value. As long as there is room for the new row on the page, the insertion does not affect any other pages in the database.

The clustered index is used to find the location for the new row.

This figure shows a simple case where there is room on an existing data page for the new row. In this case, the key values in the index do not need to change.

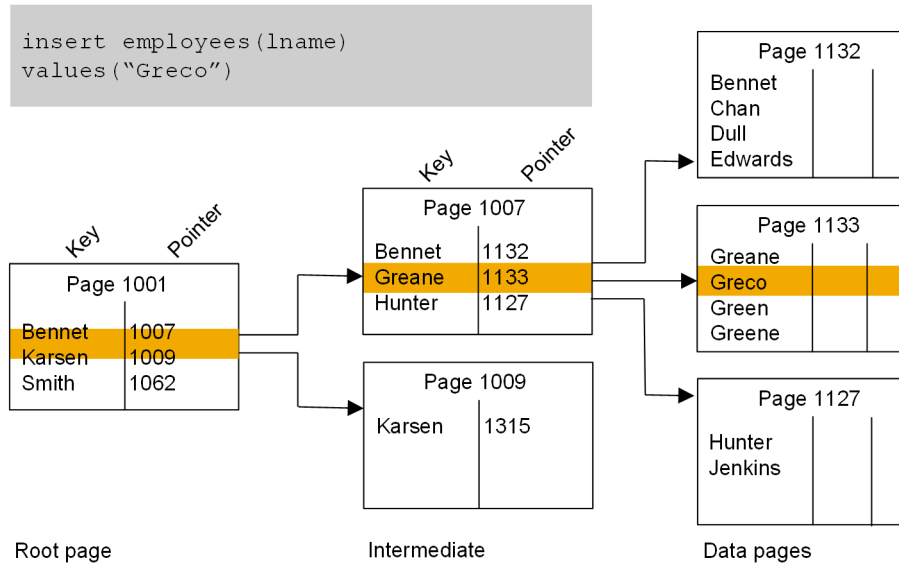

### 7.4.3 Page Splitting on Full Data Pages

If there is not enough room on the data page for the new row, a page split must be performed.

- A new data page is allocated on an extent already in use by the table. If there is no free page available, a new extent is allocated.
- The next and previous page pointers on adjacent pages are changed to incorporate the new page in the page chain. This requires reading those pages into memory and locking them.
- Approximately half of the rows are moved to the new page, with the new row inserted in order.
- The higher levels of the clustered index change to point to the new page.
- If the table also has nonclustered indexes, all pointers to the affected data rows must be changed to point to the new page and row locations.

In some cases, page splitting is handled slightly differently.

In this figure, the page split requires adding a new row to an existing index page, page 1007.

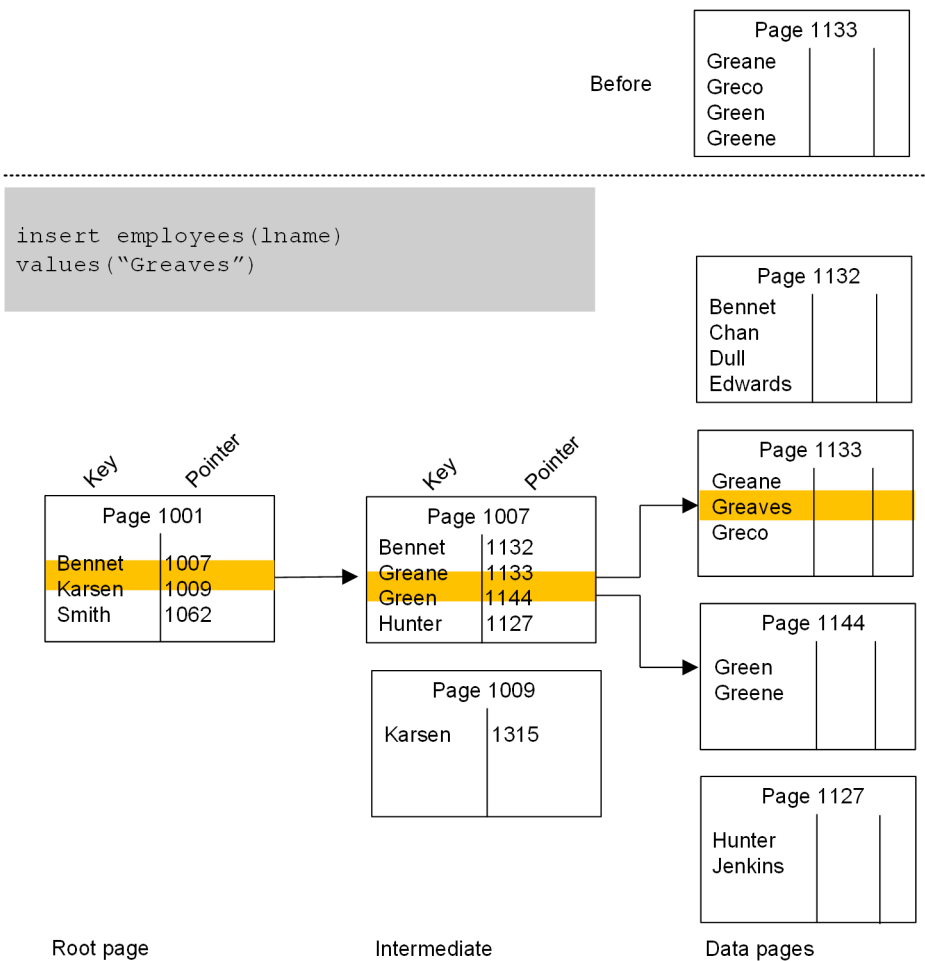

## Related Information

[Exceptions to Page Splitting \[page 103\]](#)

### 7.4.3.1 Exceptions to Page Splitting

There are exceptions to 50-50 page splits.

- If you insert a large row that cannot fit on the page before or the page after the page that requires splitting, two new pages are allocated, one for the large row and one for the rows that follow it.
- If possible, SAP ASE keeps duplicate values together when it splits pages.
- If SAP ASE detects that all inserts are taking place at the end of the page, due to an increasing key value, the page is not split when it is time to insert a new row that does not fit at the bottom of the page. Instead, a new page is allocated, and the row is placed on the new page.
- If SAP ASE detects that inserts are taking place in order at other locations on the page, the page is split at the insertion point.

## 7.4.4 Page Splitting on Index Pages

If a new row needs to be added to a full index page, the page split process on the index page is similar to the data page split.

A new page is allocated, and half of the index rows are moved to the new page.

A new row is inserted at the next highest level of the index to point to the new index page.

## 7.4.5 Performance Impacts of Page Splitting

In addition to the actual work of moving rows, allocating pages, and logging the operations, page splits are expensive operations.

The cost is increased by updating:

- The clustered index itself
- Page pointers on adjacent pages to maintain page linkage
- All nonclustered index entries that point to the rows affected by the split

When you create a clustered index for a table that will grow over time, you may want to use `fillfactor` to leave room on data pages and index pages. This reduces the number of page splits for a time.

### Related Information

[Choose Space Management Properties for Indexes \[page 134\]](#)

## 7.4.6 Overflow Pages

Special overflow pages are created for nonunique clustered indexes on allpages-locked tables when a newly inserted row has the same key as the last row on a full data page.

A new data page is allocated and linked into the page chain, and the newly inserted row is placed on the new page.



```
insert employees (lname)
values ("Greene")
```

Data pages before insert

Page 1133		
Greene		
Greco		
Green		
Greene		

Page 1134		
Gresham		
Gridley		

Overflow  
data page →

Data pages after insert

Page 1133		
Greene		
Greco		
Green		
Greene		

Page 1156		
Greene		

Page 1134		
Gresham		
Gridley		

The only rows that are placed on the overflow page are additional rows with the same key value. In a nonunique clustered index with many duplicate key values, there can be numerous overflow pages for the same value.

The clustered index does not contain pointers directly to overflow pages. Instead, the next page pointers are used to follow the chain of overflow pages until a value is found that does not match the search value.

## 7.4.7 Clustered Indexes and delete Operations

When you delete a row from an allpages-locked table that has a clustered index, other rows on the page move up to fill the empty space so that the data remains contiguous on the page.

This figure shows a page that has four rows before a `delete` operation removes the second row on the page. The two rows that follow the deleted row are moved up.

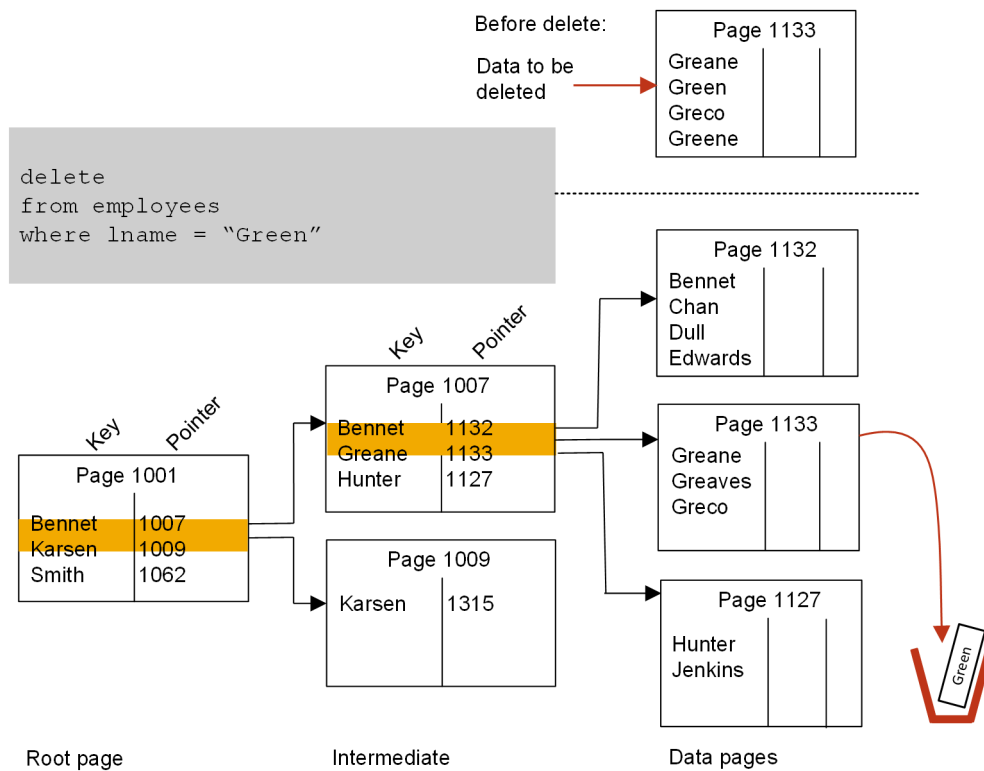

### 7.4.7.1 Deleting the Last Row on a Page

If you delete the last row on a data page, the page is deallocated and the next and previous page pointers on the adjacent pages are changed.

The rows that point to that page in the leaf and intermediate levels of the index are removed.

If the deallocated data page is on the same extent as other pages belonging to the table, it can be used again when that table needs an additional page.

If the deallocated data page is the last page on the extent that belongs to the table, the extent is also deallocated and becomes available for the expansion of other objects in the database.

This figure shows the table after the deletion, the pointer to the deleted page has been removed from index page 1007 and the following index rows on the page have been moved up to keep the used space contiguous.

```
delete
from employees
where lname =
```

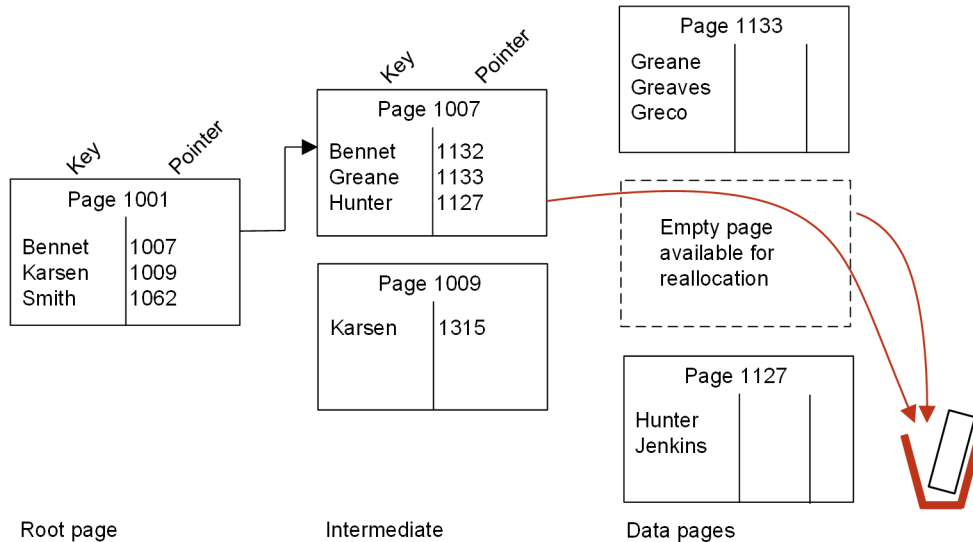

## 7.4.7.2 Index Page Merges

If you delete a pointer from an index page, leaving only one row on that page, the row is moved onto an adjacent page, and the empty page is deallocated. The pointers on the parent page are updated to reflect the changes.

## 7.5 Nonclustered Indexes

The B-tree works much the same for nonclustered indexes as it does for clustered indexes, but there are some differences.

In nonclustered indexes:

- Leaf pages are not the same as the data pages.
- Leaf level stores one key-pointer pair for each row in the table.
- Leaf-level pages store the index keys, data page number, and row number for the data row to which this index row is pointing. This combination of page number and row offset number is called the row ID.
- The root and intermediate levels store index keys and page pointers to other index pages. They also store the row ID of the key's data row.

With keys of the same size, nonclustered indexes require more space than clustered indexes.

## 7.5.1 Leaf Pages Revisited

The leaf page of an index is the lowest level of the index where all of the keys for the index appear in sorted order.

In clustered indexes on allpages-locked tables, the data rows are stored in order by the index keys, so by definition, the data level is the leaf level. There is no other level of the clustered index that contains one index row for each data row. Clustered indexes on allpages-locked tables are sparse indexes.

The level above the data contains one pointer for every data page, not data row.

In nonclustered indexes and clustered indexes on data-only-locked tables, the level just above the data is the leaf level: it contains a key-pointer pair for each data row. These indexes are dense. At the level above the data, they contain one index row for each data row.

## 7.5.2 Nonclustered Index Structure

An example showing a nonclustered index on `lname`.

The data rows at the far right show pages in ascending order by `employee_id` (10, 11, 12, and so on) because there is a clustered index on that column.

The table in shows

The root and intermediate pages store:

- The key value
- The row ID
- The pointer to the next level of the index

The leaf level stores:

- The key value
- The row ID

The row ID in higher levels of the index is used for indexes that allow duplicate keys. If a data modification changes the index key or deletes a row, the row ID positively identifies all occurrences of the key at all index levels.

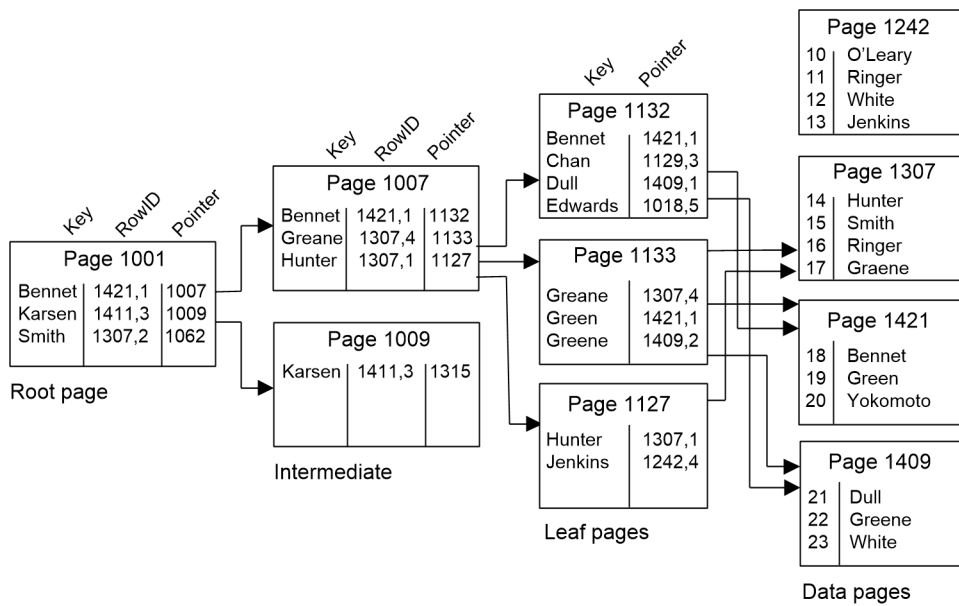

## 7.5.3 Nonclustered Indexes and select Operations

When you select a row using a nonclustered index, the search starts at the root level. `syspartitions` stores the page number for the root page of the nonclustered index (stored in `sysindexes` in SAP ASE versions earlier than 15.0).

In this figure, "Green" is greater than "Bennet," but less than "Karsen," so the pointer to page 1007 is followed.

"Green" is greater than "Greane," but less than "Hunter," so the pointer to page 1133 is followed. Page 1133 is the leaf page, showing that the row for "Green" is row 2 on page 1421. This page is fetched, the "2" byte in the offset table is checked, and the row is returned from the byte position on the data page.

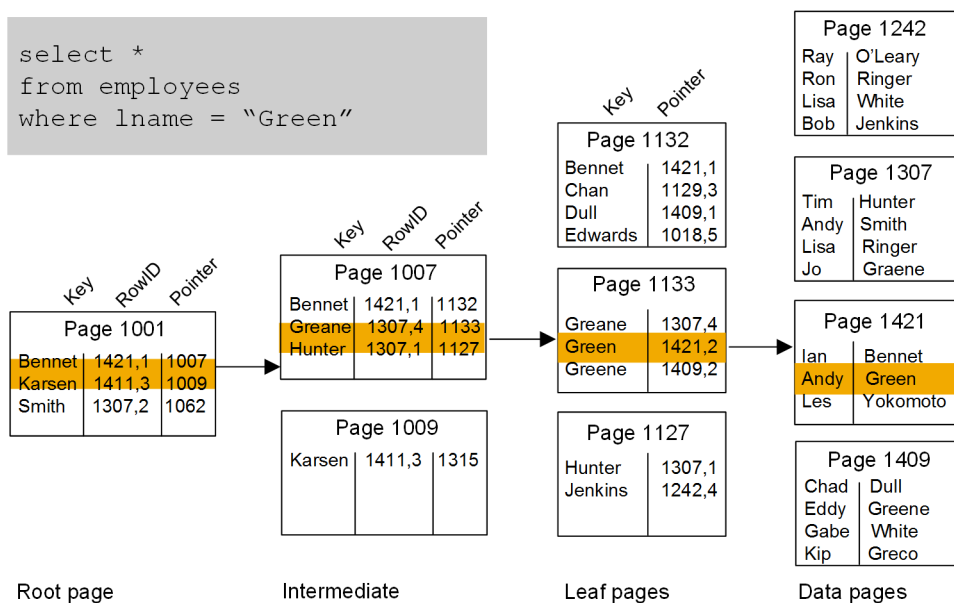

This query requires one read for each:

- Root level page
- Intermediate level page
- Leaf-level page
- Data page

If your applications use a particular nonclustered index frequently, the root and intermediate pages are probably in cache, so it is likely that only one or two physical disk I/Os need to be performed.

## 7.5.4 Nonclustered Indexes and insert Operations

When you insert rows into a heap that has a nonclustered index and no clustered index, the rows are inserted in the last page of the table.

If the heap is partitioned, the insert goes to the last page on one of the partitions. Then, the nonclustered index is updated to include the new row.

If the table has a clustered index, the clustered index is used to find the location for the row. The clustered index is updated, if necessary, and each nonclustered index is updated to include the new row.

This figure shows an insert into a heap table with a nonclustered index. The row is placed at the end of the table. A row containing the new key value and the row ID is also inserted into the leaf level of the nonclustered index.

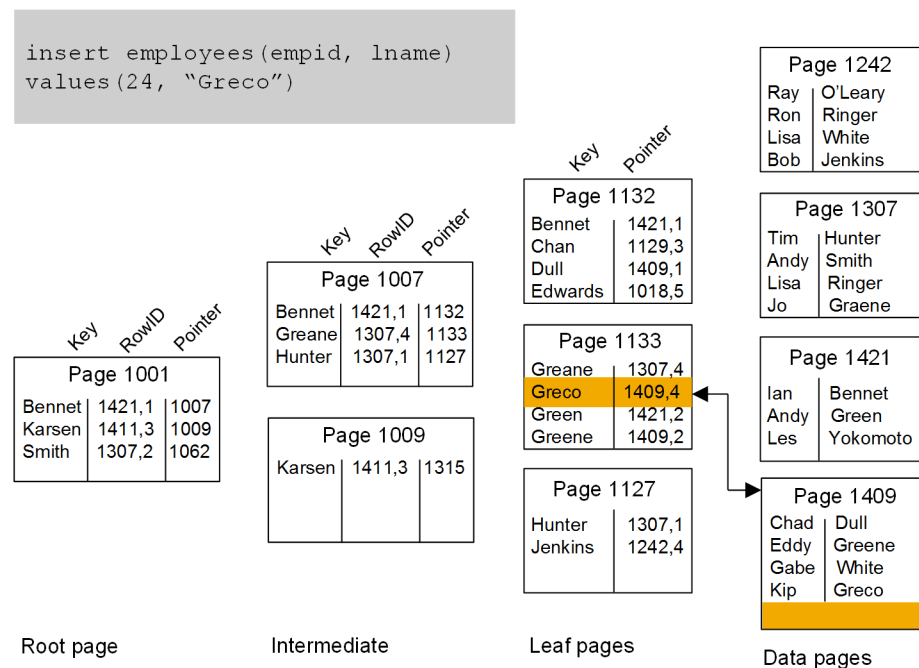

## 7.5.5 Nonclustered Indexes and delete Operations

When a row is deleted from a table, the query can use a nonclustered index on the columns in the `where` clause to locate the data row to delete.

The row in the leaf level of the nonclustered index that points to the data row is also removed. If there are other nonclustered indexes on the table, the rows on the leaf level of those indexes are also deleted.

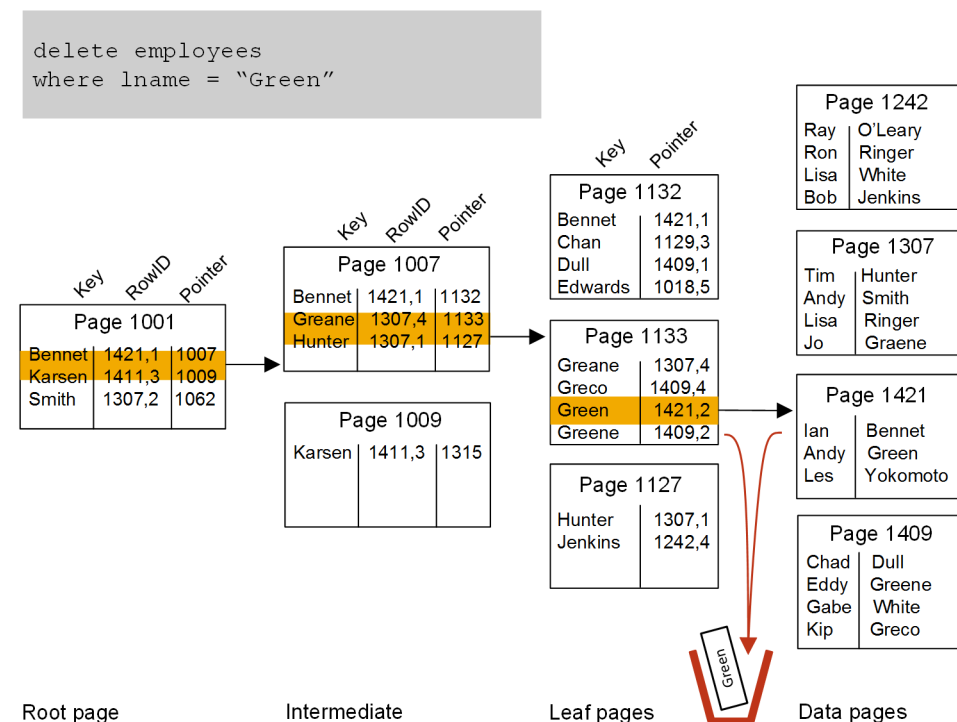

If the deletion removes the last row on the data page, the page is deallocated and the adjacent page pointers are adjusted in allpages-locked tables. Any references to the page are also deleted in higher levels of the index.

If the delete operation leaves only a single row on an index intermediate page, index pages may be merged, as with clustered indexes.

There is no automatic page merging on data pages, so if your applications make many random deletes, you may end up with data pages that have only a single row, or a few rows, on a page.

### Related Information

[Index Page Merges \[page 107\]](#)

## 7.5.6 Clustered Indexes on Data-only-locked Tables

Clustered indexes on data-only-locked tables are structured like nonclustered indexes. They have a leaf level above the data pages. The leaf level contains the key values and row ID for each row in the table.

Unlike clustered indexes on allpages-locked tables, the data rows in a data-only-locked table are not necessarily maintained in exact order by the key. Instead, the index directs the placement of rows to pages that have adjacent or nearby keys.

When a row is inserted in a data-only-locked table with a clustered index, the insert uses the clustered index key just before the value to be inserted. The index pointers are used to find that page, and the row is inserted on the page if there is room. If there is not room, the row is inserted on a page in the same allocation unit, or on another allocation unit already used by the table.

To provide nearby space for maintaining data clustering during inserts and updates to data-only-locked tables, you can set space management properties to provide space on pages (using `fillfactor` and `exp_row_size`) or on allocation units (using `reservepagegap`).

See “Setting Space Management Properties,” in *Performance and Tuning Series:Physical Database Tuning*.

## 7.6 Index Covering

Index covering can produce dramatic performance improvements when all columns needed by the query are included in the index.

You can create indexes on more than one key. These are called composite indexes. Composite indexes can have up to 400 columns, adding up to a maximum 600 bytes.

If you create a composite nonclustered index on each column referenced in the query’s `select` list and in any `where`, `having`, `group by`, and `order by` clauses, the query can be satisfied by accessing only the index.

Since the leaf level of a nonclustered index or a clustered index on a data-only-locked table contains the key values for each row in a table, queries that access only the key values can retrieve the information by using the leaf level of the nonclustered index as if it were the actual table data. This is called index covering.

Both matching and nonmatching index scans can use an index that covers a query.

### Related Information

[Composite Indexes Selection \[page 129\]](#)



## 7.6.1 Covering Matching Index Scans

Covering matching index scans lets you skip the last read for each row returned by the query, the read that fetches the data page.

For point queries that return only a single row, the query's performance gain is slight— just one page.

For range queries, the performance gain is larger, since the covering index saves one read for each row returned by the query.

For a covering matching index scan to be used, the index must contain all columns named in the query. In addition, the columns in the `where` clauses of the query must include the leading column of the columns in the index.

For example, for an index on columns A, B, C, and D, the following sets can perform matching scans: A, AB, ABC, AC, ACD, ABD, AD, and ABCD. The columns B, BC, BCD, BD, C, CD, or D do not include the leading column and can be used only for nonmatching scans.

When doing a matching index scan, SAP ASE uses standard index access methods to move from the root of the index to the nonclustered leaf page that contains the first row.

In this figure, the nonclustered index on `lname`, `fname` covers the query. The `where` clause includes the leading column, and all columns in the `select` list are included in the index, so the data page need not be accessed.

```
select fname, lname
from employees
where lname =
```

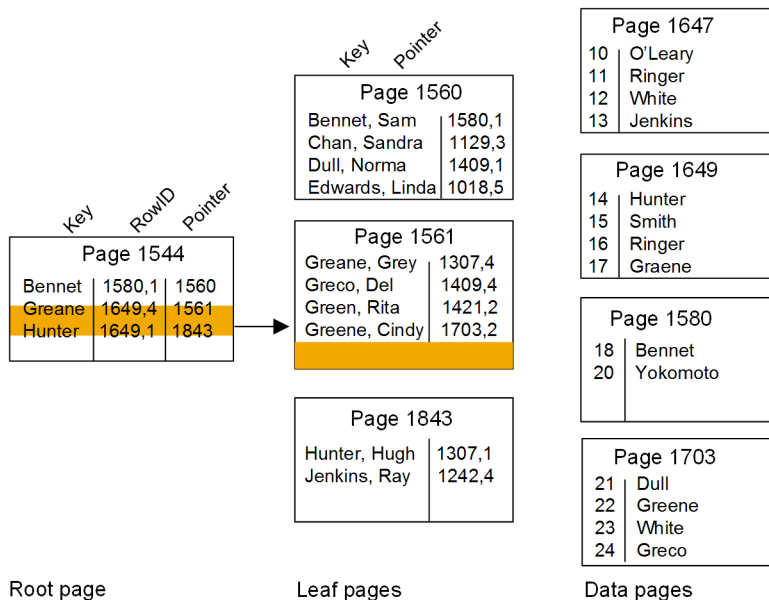

## 7.6.2 Covering Nonmatching Index Scans

SAP ASE saves I/O by scanning the entire leaf level of the index, rather than scanning the table in certain scenarios.

When the columns specified in the `where` clause do not include the leading column in the index, but all columns named in the select list and other query clauses (such as `group by` or `having`) are included in the index, SAP ASE saves I/O by scanning the entire leaf level of the index, rather than scanning the table.

It cannot perform a matching scan because the first column of the index is not specified.

The query in the following figure shows a nonmatching index scan. This query does not use the leading columns on the index, but all columns required in the query are in the nonclustered index on `lname`, `fname`, `emp_id`.

The nonmatching scan must examine all rows on the leaf level. It scans all leaf level index pages, starting from the first page. It has no way of knowing how many rows might match the query conditions, so it must examine every row in the index. Since it must begin at the first page of the leaf level, it can use the pointer in `syspartitions.firstpage` rather than descend the index.

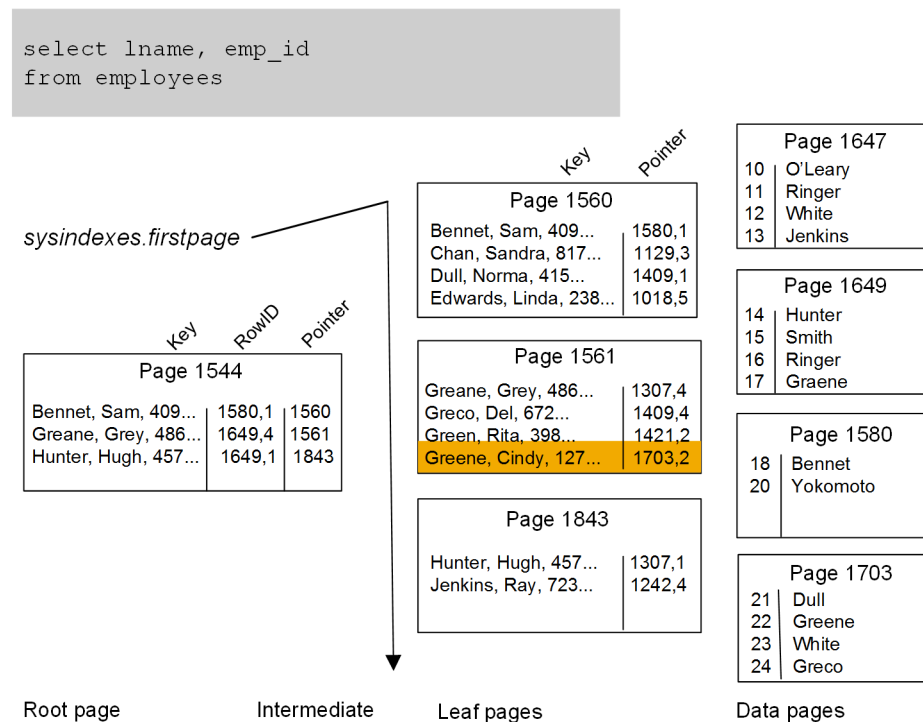

## 7.7 Indexes and Caching

Index pages get special handling in the data cache in certain scenarios.

- Root and intermediate index pages always use least recently used (LRU) strategy.
- Index pages can use one cache while the data pages use a different cache, if the index is bound to a different cache.
- Covering index scans can use fetch-and-discard strategy.
- Index pages can cycle through the cache many times, if `number of index trips` is configured.

When a query that uses an index is executed, the root, intermediate, leaf, and data pages are read in that order. If these pages are not in cache, they are read into the MRU end of the cache and are moved toward the LRU end as additional pages are read in.

Each time a page is found in cache, it is moved to the MRU end of the page chain, so the root page and higher levels of the index tend to stay in the cache.

"How SAP ASE performs I/O for heap operations" in *Performance and Tuning Series: Physical Database Tuning* introduces the basic concepts of the SAP ASE data cache, and shows how caches are used when reading heap tables.

### 7.7.1 Using Separate Caches for Data and Index Pages

Indexes and the tables they index can use different caches. A system administrator or table owner can bind a clustered or nonclustered index to one cache and its table to another.

### 7.7.2 Index Trips Through the Cache

Data pages make only a single trip through the cache: they are read in at the MRU end of the cache or placed immediately before the wash marker (A point in the cache on the MRU/LRU chain), depending on the cache strategy chosen for the query.

Once the pages reach the LRU end of the cache, the buffer for that page is reused when another page needs to be read into cache.

For index pages, a counter controls the number of trips that an index page can make through the cache.

When the counter is greater than 0 for an index page, and it reaches the LRU end of the page chain, the counter is decremented by 1, and the page is placed at the MRU end again.

By default, the number of trips that an index page makes through the cache is set to 0. To change the default, a system administrator can set the `number of index trips` configuration parameter.

# 8 Indexing for Concurrency Control

Basic query analysis tools can help you choose appropriate indexes. It also discusses index selection criteria for point queries, range queries, and joins.

## 8.1 Indexes and Performance

Carefully considered indexes, built on top of a good database design, are the foundation of a high-performance SAP ASE installation. However, adding indexes without proper analysis can reduce the overall performance of your system.

Insert, update, and delete operations can take longer when a large number of indexes must be updated.

Analyze your application workload and create indexes as necessary to improve the performance of the most critical processes.

The SAP ASE query optimizer analyzes the costs of possible query plans and chooses the plan that has the lowest estimated cost. Since much of the cost of executing a query consists of disk I/O, creating the correct indexes for your applications means that the optimizer can use indexes to:

- Avoid table scans when accessing data
- Target specific data pages that contain specific values in a point query
- Establish upper and lower bounds for reading data in a range query
- Avoid data page access completely, when an index covers a query
- Use ordered data to avoid sorting data or to favor the less costly ordered-input based `JOIN`, `UNION`, `GROUP`, or `DISTINCT` operators over other more expensive algorithms (for example, using merge joins instead of nested-loop joins and so on).

For example, to select the best index for a `join` clause:

```
r.c1=s.c1 and ... r.cn=s.cn
```

- Indexes on `r` or `s` that have any subset of `c1 ... cn` as a prefix avoid the `sort` on the side of the merge join with the prefix.
- You can use indexes on both sides of the `and` clause if they are compatible (that is, they have a nonempty common prefix covered by the `equijoin` clause. This common prefix determines the part of the `equijoin` clause used as a merge clause (the longer the merge clause, the more effective it is).
- The query processor enumerates plans with an index on one side and a `sort` on the other. In the example above, the index prefix covered by the `equijoin` clause determines the part of the `equijoin` clause used as a merge clause (again, the longer the merge clause, the more effective it is).

You can use similar steps to identify the best index for `union`, `distinct`, and `group` clauses.

You can create indexes to enforce the uniqueness of data and to randomize the storage location of inserts.

You can set `sp_chgattribute 'concurrency_opt_threshold'` parameter to avoid table scans for increased concurrency. The syntax is:

```
sp_chgattribute <table_name>, "concurrency_opt_threshold", <min_page_count>
```

For example, this sets the concurrency optimization threshold for a table to 30 pages:

```
sp_chgattribute lookup_table, "concurrency_opt_threshold", 30
```

## 8.2 Detecting Indexing Problems

Major indications of insufficient or incorrect indexing.

- A `select` statement takes too long.
- A join between two or more tables takes an extremely long time.
- `select` operations perform well, but data modification processes perform poorly.
- Point queries (for example, `where colvalue = 3`) perform well, but range queries (for example, `where colvalue > 3 and colvalue < 30`) perform poorly.

These underlying problems are described in the following sections.

### 8.2.1 Symptoms of Poor Indexing

A primary goal of improving performance with indexes is avoiding table scans (which read every page of the table from disk), or partial table scans, which read only data pages from disk.

A query searching for a unique value in a table that has 600 data pages requires 600 physical and logical reads. If an index points to the data value, the same query can be satisfied with 2 or 3 reads, a 200 to 300 fold performance improvement

On a system with a 12-millisecond disk, this is a difference of several seconds compared to less than a second. Heavy disk I/O by a single query has a negative impact on overall throughput.

#### 8.2.1.1 Lack of Indexes is Causing Table Scans

If select operations and joins take too long, it probably indicates that either an appropriate index does not exist or, it exists, but is not being used by the optimizer.

`showplan` output reports whether the table is being accessed by a table scan or index. If you think an index should be used but `showplan` reports a table scan:

- In default mode – enable `set show_lio_costing`, which shows estimates of logical input and output
- In compatibility mode – `dbcc traceon(302)` output can help you determine the reason. `dbcc traceon` displays the costing computations for all optimizing query clauses

If there is no clause is included in `dbcc traceon(302)` output, there may be problems with the way the clause is written. If a clause that you think should limit the scan is included in `dbcc traceon(302)` output, look carefully at its costing, and that of the chosen plan reported with `dbcc traceon(310)`.

See Chapter 3, “Displaying Query Optimization Strategies and Estimates” in *Performance and Tuning Series: Query Processing and Abstract Plans* for information about using `set show_ljo_costing`. See *SAP ASE Reference Manual: Commands* for more information about `dbcc traceon` and `set show_ljo_costing`.

## 8.2.1.2 Index is Not Selective Enough

An index is selective if it helps the optimizer find a particular row or a set of rows. An index on a unique identifier such as a passport number is highly selective, since it lets the optimizer pinpoint a single row.

An index on a nonunique entry such as sex (M, F) is not very selective, and the optimizer uses such an index only in very special cases.

## 8.2.1.3 Index Does Not Support Range Queries

Generally, clustered indexes and covering indexes provide good performance for range queries and for search arguments that match many rows. Range queries that reference the keys of noncovering indexes use the index for ranges that return a limited number of rows.

As the number of rows the query returns increases, however, using a nonclustered index or a clustered index on a data-only-locked table can cost more than a table scan.

## 8.2.1.4 Too Many Indexes Slow Data Modification

If data modification performance is poor, you may have too many indexes. While indexes favor select operations, they slow down data modifications.

Every insert or delete operation affects the leaf level, (and sometimes higher levels) of a clustered index on a data-only-locked table, and each nonclustered index, for any locking scheme.

Updates to clustered index keys on allpages-locked tables can move the rows to different pages, requiring an update of every nonclustered index. Analyze the requirements for each index and try to eliminate those that are unnecessary or rarely used.

## 8.2.1.5 Index Entries are Too Large

Guidelines to help reduce index entries.

Try to keep index entries as small as possible. You can create an index's total key length up to one-third the page size. However, indexes with this key length can store very few rows per index page, and the index level may

be high. This increases the number of pages to traverse from the index root to the leaf pages, and increases the amount of disk I/O needed during queries.

The following example uses values reported by `sp_estspace` to demonstrate how the number of index pages and leaf levels required increases with key size. It creates nonclustered indexes using 10-, 20-, and 40-character keys on a server configured for 2K pages.

```
create table demotable (c10 char(10),
                       c20 char(20),
                       c40 char(40))
```

```
create index t10 on demotable(c10)
```

```
create index t20 on demotable(c20)
```

```
create index t40 on demotable(c40)
```

```
sp_estspace demotable, 500000
```

Table 9: Effects of Key Size on Index Size and Levels

Index, Key Size	Leaf-level Pages	Index Levels
t10, 10 bytes	4311	3
t20, 20 bytes	6946	3
t40, 40 bytes	12501	4

The output shows that the indexes for the 10-column and 20-column keys each have three levels, while the 40-column key requires a fourth level.

The number of pages required is more than 50 percent higher at each level.

## 8.2.1.6 Exception for Wide Data Rows and Wide Index Rows

Occasionally, indexes with wide rows may be useful.

When:

- The table has very wide rows, resulting in very few rows per data page.
- The set of queries run on the table provides logical choices for a covering index.
- Queries return a sufficiently large number of rows.

For example, if a table has very long rows, and only one row per page, a query that needs to return 100 rows must access 100 data pages. An index that covers this query, even with long index rows, can improve performance.

For example, if the index rows are 240 bytes, the index stores 8 rows per page, and the query must access only 12 index pages.

## 8.3 Fixing Corrupted Indexes

If the index on one of your system tables has been corrupted, you can use the `sp_fixindex` system procedure to repair the index.

### Procedure

1. Get the `<object_name>`, `<object_ID>`, and `<index_ID>` of the corrupted index. If you only have a page number and you need to find the `object_name`, see the *SAP ASE Troubleshooting and Error Messages Guide* for instructions.
2. If the corrupted index is on a system table in the `master` database, put SAP ASE in single-user mode. See the *SAP ASE Troubleshooting and Error Messages Guide* for instructions.
3. If the corrupted index is on a system table in a user database, put the database in single-user mode and reconfigure to allow updates to system tables:

```
1> use master
2> go
```

```
1> sp_dboption database_name, "single user", true
2> go
```

```
1> sp_configure "allow updates", 1
2> go
```

4. Issue the `sp_fixindex` command:

```
1> use database_name
2> go
1> checkpoint
2> go
1> sp_fixindex database_name, object_name, index_ID
2> go
```

You can use the `checkpoint` to identify the one or more databases or use an `all` clause.

```
checkpoint [all | [dbname[, dbname[, dbname.....]]]
```

#### Note

You must be assigned `sa_role` to run `sp_fixindex`.

5. Run `dbcc checktable` to verify that the corrupted index is now fixed.
6. Disallow updates to system tables:

```
1> use master
2> go
1> sp_configure "allow updates", 0
2> go
```



7. Turn off single-user mode:

```
1> sp_dboption database_name, "single user", false
2> go
1> use database_name
2> go
1> checkpoint
2> go
```

You can use the `checkpoint` to identify the one or more databases or use an `all` clause, which means you do not have to issue the `use database` command.

```
checkpoint [all | [dbname[, dbname[, dbname.....]]]
```

See *SAP ASE Reference Manual: Procedures*.

## 8.3.1 Repairing a Nonclustered Index on sysobjects

Steps to repair a nonclustered index.

### Procedure

1. Get the `<object_name>`, `<object_ID>`, and `<index_ID>` of the corrupted index. If you only have a page number and you need to find the `object_name`, see the *SAP ASE Troubleshooting and Error Messages Guide* for instructions.
2. If the corrupted index is on a system table in the `master` database, put SAP ASE in single-user mode. See the *SAP ASE Troubleshooting and Error Messages Guide* for instructions.
3. If the corrupted index is on a system table in a user database, put the database in single-user mode and reconfigure to allow updates to system tables:

```
1> use master
2> go
```

```
1> sp_dboption database_name, "single user", true
2> go
```

```
1> sp_configure "allow updates", 1
2> go
```

4. Issue:

```
1> use database_name
2> go1> checkpoint
2> go1> select sysstat from sysobjects
2> where id = 1
3> go
```

You can use the `checkpoint` to identify the one or more databases or use an `all` clause.

```
checkpoint [all | [dbname[, dbname[, dbname.....]]]
```

5. Save the original `sysstat` value.
6. Change the `sysstat` column to the value required by `sp_fixindex`:

```
1> update sysobjects
2> set sysstat = sysstat | 4096
3> where id = 1
4> go
```

7. Run:

```
1> sp_fixindex database_name, sysobjects, 2
2> go
```

8. Restore the original `sysstat` value:

```
1> update sysobjects
2> set sysstat = sysstat_ORIGINAL
3> where id = object_ID
4> go
```

9. Run `dbcc checktable` to verify that the corrupted index is now fixed.

10. Disallow updates to system tables:

```
1> sp_configure "allow updates", 0
2> go
```

11. Turn off single-user mode:

```
1> sp_dboption database_name, "single user", false
2> go1> use database_name
2> go1> checkpoint
2> go
```

You can use the `checkpoint` to identify the one or more databases or use an `all` clause.

```
checkpoint [all | [dbname[, dbname[, dbname.....]]]
```

## 8.4 Index Limits and Requirements

Limits that apply to indexes in SAP ASE.

- Because the data for a cluster index is ordered by index key, you can create only one clustered index per table. SAP ASE creates a clustered index by default as a local index for range-, list-, and hash-partitioned tables. You cannot create global clustered indexes on range-, list-, or hash-partitioned tables.
- You can create a maximum of 249 nonclustered indexes per table.
- When you create a clustered index, SAP ASE requires empty free space to copy the rows in the table and allocate space for the clustered index pages. It also requires space to re-create any nonclustered indexes on the table.

The amount of space required can vary, depending on how full the table's pages are when you begin and the space management properties are applied to the table and index pages.

See "Determining the space available for maintenance activities" in "Database Maintenance," in *Performance and Tuning Series: Physical Database Tuning*.

- The referential integrity constraints `unique` and `primary key` create unique indexes to enforce their restrictions on the keys. By default, `unique` constraints create nonclustered indexes and `primary key` constraints create clustered indexes.
- 
- A key can be made up of as many as 31 columns. The maximum number of bytes per index key is varies by the page size in bytes as follows:

Page Size	Max Key Length
2048	600
4096	1250
8192	2600
16384	5300

## 8.5 Index Choices

Items to consider when you choose an index.

When you are working with index selection you may want to ask these questions:

- What indexes are associated currently with a given table?
- What are the most important processes that make use of the table?
- What is the ratio of `select` operations to data modifications performed on the table?
- Has a clustered index been created for the table?
- Can the clustered index be replaced by a nonclustered index?
- Do any of the indexes cover one or more of the critical queries?
- Is a composite index required to enforce the uniqueness of a compound primary key?
- Do existing queries contain expressions that could be accelerated by using function-based indexes?
- What indexes can be defined as unique?
- What are the major sorting requirements?
- Do some queries use descending ordering of result sets?
- Do the indexes support joins and referential integrity checks?
- Does indexing affect update types (direct versus deferred)?
- What indexes are needed for cursor positioning?
- If dirty reads are required, are there unique indexes to support the scan?
- Should `IDENTITY` columns be added to tables and indexes to generate unique indexes? Unique indexes are required for updatable cursors and dirty reads.

When deciding how many indexes to use, consider:

- Space constraints
- Access paths to table
- Percentage of data modifications versus select operations
- Performance requirements of reports versus OLTP

- Performance impacts of index changes
- How often you can use `update statistics`

## 8.5.1 Index Keys and Logical Keys

You must differentiate index keys from logical keys. Logical keys are part of the database design, defining the relationships between tables: primary keys, foreign keys, and common keys.

When you optimize your queries by creating indexes, the logical keys may or may not be used as the physical keys for creating indexes. You can create indexes on columns that are not logical keys, and you may have logical keys that are not used as index keys.

Choose index keys for performance reasons. Create indexes on columns that support the joins, search arguments, and ordering requirements in queries.

A common error is to create the clustered index for a table on the primary key, even though it is never used for range queries or ordering result sets.

## 8.5.2 Guidelines for Clustered Indexes

General guidelines for clustered indexes.

- Most allpages-locked tables should have clustered indexes or use partitions to reduce contention on the last page of heap tables.  
In a high-transaction environment, the locking on the last page severely limits throughput.
- If your environment requires a lot of inserts, do not place the clustered index key on a steadily increasing value such as an `IDENTITY` column. Instead, choose a key that places inserts on random pages to minimize lock contention while remaining useful in many queries. Often, the primary key does not meet this condition.  
This problem is less severe on data-only-locked tables, but is often a major source of lock contention on allpages-locked tables.
- Clustered indexes provide very good performance when the key matches the search argument in range queries, such as:

```
where colvalue >= 5 and colvalue < 10
```

In allpages-locked tables, rows are maintained in key order and pages are linked in order, providing very fast performance for queries using a clustered index.

In data-only-locked tables, rows are in key order after the index is created, but the clustering can decline over time.

- Other good choices for clustered index keys are columns used in `order by` clauses and in joins.
- If possible, do not include frequently updated columns as keys in clustered indexes on allpages-locked tables.

When the keys are updated, the rows must be moved from the current location to a new page. Also, if the index is clustered, but not unique, updates are performed in deferred mode.

## 8.5.3 Clustered Index Selection

Choose indexes based on the kinds of `where` clauses or joins you perform.

Choices for clustered indexes are:

- The primary key, if it is used for `where` clauses and if it randomizes inserts
- Columns that are accessed by range, such as:

```
col1 between 100 and 200
```

```
col12 > 62 and < 70
```

- Columns used by `order by`
- Columns that change infrequently
- Columns used in joins

If there are several possible choices, choose the most commonly needed physical order as a first choice.

As a second choice, look for range queries. During performance testing, check for “hot spots” due to lock contention.

## 8.5.4 Candidates for Nonclustered Indexes

When choosing columns for nonclustered indexes, consider all the uses that were not satisfied by your clustered index choice. In addition, look at columns that can provide performance gains through index covering.

On data-only-locked tables, clustered indexes can perform index covering, since they have a leaf level above the data level.

On allpages-locked tables, noncovered range queries work well for clustered indexes, but may not be supported by nonclustered indexes, depending on the size of the range.

Consider using composite indexes to cover critical queries and to support less frequent queries:

- The most critical queries should be able to perform point queries and matching scans.
- Other queries should be able to perform nonmatching scans using the index, which avoids table scans.

## 8.5.5 Function-based Indexes Selection

Function-based indexes can provide an inexpensive option for enhancing the performance of certain legacy applications.

Function-based indexes allow you to create indexes based directly on one or more expressions (see the *Transact-SQL Users Guide*). When the index is built, the result of evaluating the expressions for each row is stored as an index key value, and is not reevaluated at query execution time. This means lookups on the result of an expression within a SQL query can be very fast. Without function-based indexes, table scans are typically required to evaluate the expression for each row in the table for comparison. SAP ASE creates a hidden computed column containing the evaluated key expressions and indexes this column.

You can effectively use function-based indexes for queries that need to apply a function or operation to a column value and compare the result to another column in the same row or to a constant or variable.

You can also obtain the performance benefits of function-based indexes by adding a materialized computed column with index to a table and rewriting the query to use the indexed computed column. This can be a good approach for new application development. The advantage of function-based indexes is that you can simply add to an existing table an index that matches expressions used in existing queries. In this way, you can enhance the performance of legacy applications with a minimal schema addition and no change to SQL query code.

## 8.5.6 Index Selection

Index selection allows you to determine which indexes are actively being used and those that are rarely used.

This section assumes that the monitoring tables feature is already set up. See the *Performance and Tuning Series: Monitoring Tables* for information about installing and using the monitoring tables.

Index selection uses these columns of the monitoring access table, `monOpenObjectActivity`:

- `IndexID` – unique identifier for the index.
- `OptSelectCount` – reports the number of times that the corresponding object (such as a table or index) was used as the access method by the optimizer.
- `LastOptSelectDate` – reports the last time `OptSelectCount` was incremented.
- `UsedCount` – reports the number of times that the corresponding object (such as a table or index) was used as an access method when a query executed.
- `LastUsedDate` – reports the last time `UsedCount` was incremented.

If a plan has already been compiled and cached, `OptSelectCount` is not incremented each time the plan is executed. However, `UsedCount` is incremented when a plan is executed. If `no_exec` is on, `OptSelectCount` is incremented, but `UsedCount` is not.

Monitoring data is nonpersistent. That is, when you restart the server, the monitoring data is reset. Monitoring data is reported only for active objects. For example, monitoring data does not exist for objects that have not been opened, since there are no active object descriptors for such objects. If the system is inadequately configured and has reused object descriptors, monitoring data for these object descriptors is reinitialized and the data for the previous object is lost. When the old object is reopened, its monitoring data is reset.

### 8.5.6.1 Examples of Using Index Selection

Index selection examples.

The following example queries the monitoring tables for the last time all indexes for a specific object were selected by the optimizer, as well as the last time they were actually used during execution, and reports the counts in each case:

```
select DBID, ObjectID, IndexID, OptSelectCount, LastOptSelectDate, UsedCount,
LastUsedDate
from monOpenObjectActivity
```

```

where DBID=db_id("financials_db") and ObjectID =
object_id('financials_db..expenses')
order by UsedCount

```

This example displays all indexes that are used—or not currently used—in an application:

```

select DBID, ObjectID, IndexID, ObjectName = object_name(ObjectID, DBID),
LastOptSelectDate, UsedCount, LastUsedDate
from monOpenObjectActivity
where DBID = db_id("MY_1253_RS_RSSD")
and ObjectID = object_id('MY_1253_RS_RSSD..rs_columns')

```

DBID	ObjectID	IndexID	ObjectName
LastOptSelectDate		UsedCount	LastUsedDate
4	192000684	0	rs_columns
May 15 2006 4:18PM	4:18PM	450	May 15 2006 4:18PM
4	192000684	1	rs_columns
NULL		0	NULL
4	192000684	2	rs_columns
NULL		0	NULL
4	192000684	3	rs_columns
May 12 2006 6:11PM	6:11PM	1	May 12 2006 6:11PM
4	192000684	4	rs_columns
NULL		0	NULL
4	192000684	5	rs_columns
NULL		0	NULL

If the index is not used, it results in a NULL date. If an index is used, it results in a date like “May 15 2006 4:18PM.”

In this example, the query displays all indexes that are not currently used in the current database:

```

select DB = convert(char(20), db_name()),
TableName = convert(char(20), object_name(i.id, db_id())),
IndexName = convert(char(20), i.name),
IndID = i.indid
from master..monOpenObjectActivity a, sysindexes i
where a.ObjectID =* i.id
and a.IndexID =* i.indid
and (a.UsedCount = 0 or a.UsedCount is NULL)
and i.indid > 0
and object_name(i.id, db_id()) not like "sys%"
order by 2, 4 asc

```

DB	TableName	IndexName	IndID
MY_1253_RS_RSSD	rs_articles	rs_key_articles	1
MY_1253_RS_RSSD	rs_articles	rs_key4_articles	2
MY_1253_RS_RSSD	rs_classes	rs_key_classes	1
MY_1253_RS_RSSD	rs_classes	rs_key2_classes	2
MY_1253_RS_RSSD	rs_config	rs_key_config	1
MY_1253_RS_RSSD	rs_databases	rs_key_databases	1
MY_1253_RS_RSSD	rs_databases	rs_key9_databases	2
MY_1253_RS_RSSD	rs_databases	rs_key13_databases	3
MY_1253_RS_RSSD	rs_databases	rs_key14_databases	4
MY_1253_RS_RSSD	rs_databases	rs_key15_databases	5
MY_1253_RS_RSSD	rs_datatype	rs_key_datatypes	1
MY_1253_RS_RSSD	rs_datatype	rs_key2_datatype	2

## 8.5.7 Other Indexing Guidelines

Additional considerations for choosing indexes.

- If an index key is unique, define it as unique so the optimizer knows immediately that only one row matches a search argument or a join on the key.
- If your database design uses referential integrity (the `references` keyword or the `foreign key...references` keywords in the `create table` statement), the referenced columns must have a unique index, or the attempt to create the referential integrity constraint fails. However, SAP ASE does not automatically create an index on the referencing column. If your application updates primary keys or deletes rows from primary key tables, you may want to create an index on the referencing column so that these lookups do not perform a table scan.
- If your applications use cursors, see “Index use and requirements for cursors” in “Optimization for Cursors” in *Performance and Tuning Series: Query Processing and Abstract Plans*.
- If you are creating an index on a table that will have a lot of `insert` activity, use `fillfactor` to temporarily minimize page splits, improve concurrency, and minimize deadlocking.
- If you are creating an index on a read-only table, use a `fillfactor` of 100 to make the table or index as compact as possible.
- Keep the size of the key as small as possible. Your index trees remain flatter, accelerating tree traversals.
- Use small datatypes whenever it fits your design.
  - Internally, numerics compare slightly faster than strings.
  - Variable-length character and binary types require more row overhead than fixed-length types, so if there is little difference between the average length of a column and the defined length, use fixed length. Character and binary types that accept null values are, by definition, variable-length.
  - Whenever possible, use fixed-length, nonnull types for short columns that will be used as index keys.
- Be sure that the datatypes of the join columns in different tables are compatible. If SAP ASE has to convert a datatype on one side of a join, it may not use an index for that table.

## 8.5.8 Nonclustered Indexes Selection

When you consider adding nonclustered indexes, you must weigh the improvement in retrieval time against the increase in data modification time.

In addition, consider:

- How much space will the indexes use?
- How volatile is the candidate column?
- How selective are the index keys? Would a scan be better?
- Are there a lot of duplicate values?

Because of data modification overhead, add nonclustered indexes only when your testing shows that they are helpful.



## 8.5.8.1 Performance Price for Data Modification

For all locking schemes, each nonclustered index needs to be updated for each insertion into, and each deletion from, the table

An update to the table that changes part of an index's key requires only that index be updated.

For tables that use allpages locking, all indexes need to be updated for:

- Any update that changes the location of a row by updating a clustered index key so that the row moves to another page
- Every row affected by a data page split

For allpages-locked tables, exclusive locks are held on affected index pages for the duration of the transaction, increasing lock contention as well as processing overhead.

Some applications experience unacceptable performance impacts with only three or four indexes on tables that experience heavy data modification. Other applications can perform well with many more tables.

## 8.5.9 Composite Indexes Selection

If your analysis shows that more than one column is a good candidate for a clustered index key, you may be able to provide clustered-like access with a composite index that covers a particular query or set of queries.

These include:

- Range queries.
- Vector (grouped) aggregates, if both the grouped and grouping columns are included. Any search arguments must also be included in the index.
- Queries that return a high number of duplicates.
- Queries that include `order by`.
- Queries that table scan, but use a small subset of the columns on the table.

Tables that are read-only or read-mostly can be heavily indexed, as long as your database has enough space available. If there is little update activity and high select activity, provide indexes for all frequently used queries. Be sure to test the performance benefits of index covering.

## 8.5.10 Key Order and Performance in Composite Indexes

Covered queries can provide excellent response time for specific queries when the leading columns are used.

With the composite nonclustered index on `au_lname`, `au_fname`, `au_id`, this query runs very quickly:

```
select au_id
  from authors
 where au_fname = "Eliot" and au_lname = "Wilk"
```

This covered point query needs to read only the upper levels of the index and a single page in the leaf-level row in the nonclustered index of a 5000-row table.

This similar-looking query (using the same index) does not perform quite as well. This query is still covered, but searches on `au_id`:

```
select au_fname, au_lname
from authors
where au_id = "A1714224678"
```

Since this query does not include the leading column of the index, it has to scan the entire leaf level of the index, about 95 reads.

Adding a column to the select list in the query above, which may seem like a minor change, makes the performance even worse:

```
select au_fname, au_lname, phone
from authors
where au_id = "A1714224678"
```

This query performs a table scan, reading 222 pages. In this case, the performance is noticeably worse. For any search argument that is not the leading column, SAP ASE has only two possible access methods: a table scan, or a covered index scan.

It does not scan the leaf level of the index for a nonleading search argument and then access the data pages. A composite index can be used only when it covers the query or when the first column appears in the `where` clause.

For a query that includes the leading column of the composite index, adding a column that is not included in the index adds only a single data page read. This query must read the data page to find the phone number:

```
select au_id, phone
from authors
where au_fname = "Eliot" and au_lname = "Wilk"
```

This table shows the performance characteristics of different `where` clauses with a nonclustered index on `au_lname`, `au_fname`, `au_id` and no other indexes on the table.

Columns in the <code>where</code> Clause	Performance with the Indexed Columns in the Select List	Performance with Other Columns in the Select List
<code>au_lname</code> or <code>au_lname, au_fname</code> or <code>au_lname, au_fname, au_id</code>	Good; index used to descend tree; data level is not accessed	Good; index used to descend tree; data is accessed (one more page read per row)
<code>au_fname</code> or <code>au_id</code> or <code>au_fname, au_id</code>	Moderate; index is scanned to return values	Poor; index not used, table scan

Choose the ordering of the composite index so that most queries form a prefix subset.

## 8.5.11 Advantages and Disadvantages of Composite Indexes

Pros and cons of composite indexes and recommendations for its use.

Composite indexes have these advantages:

- A composite index provides opportunities for index covering.
- If queries provide search arguments on each of the keys, the composite index requires fewer I/Os than the same query using an index on any single attribute.
- A composite index is a good way to enforce the uniqueness of multiple attributes.

Good choices for composite indexes are:

- Lookup tables
- Columns that are frequently accessed together
- Columns used for vector aggregates
- Columns that make a frequently used subset from a table with very wide rows

The disadvantages of composite indexes are:

- Composite indexes tend to have large entries. This means fewer index entries per index page and more index pages to read.
- An update to any attribute of a composite index causes the index to be modified. The columns you choose should not be those that are updated often.

Poor choices are:

- Index rows that are nearly as wide as the data rows
- Composite indexes where only a minor key is used in the `where` clause

## 8.5.12 online reorg rebuild for Data-only-locked Indexes

You can run `online reorg rebuild index` on DOL indexes to recompact the data, collect garbage from spaces left by previous deallocations, and rearrange the data to improve the index page clustering ratio.

Running `online reorg rebuild index` reduces the space an index requires, and improves the query execution with higher clustering.

## 8.6 Techniques for Choosing Indexes

A study of two queries that must access a single table, and the indexing choices for these two queries.

The two queries are:

- A range query that returns a large number of rows
- A point query that returns only one or two rows

## 8.6.1 Index Choice for a Range Query

Reasons why you would choose a particular index for a range query.

Assume that you need to improve the performance of the following query:

```
select title
from titles
where price between $20.00 and $30.00
```

Some basic statistics on the table are:

- The table has 1,000,000 rows, and uses allpages locking.
- There are 10 rows per page; pages are 75 percent full, so the table has approximately 135,000 pages.
- 190,000 (19%) of the titles are priced between \$20 and \$30.

With no index, the query would scan all 135,000 pages.

With a clustered index on `price`, the query would find the first \$20 book and begin reading sequentially until it gets to the last \$30 book. With pages about 75 percent full, the average number of rows per page is 7.5. To read 190,000 matching rows, the query would read approximately 25,300 pages, plus 3 or 4 index pages.

With a nonclustered index on `price` and random distribution of `price` values, using the index to find the rows for this query requires reading about 19 percent of the leaf level of the index; about 1,500 pages.

If the price values are randomly distributed, the number of data pages that must be read is likely to be high, perhaps as many data pages as there are qualifying rows, 190,000. Since a table scan requires only 135,000 pages, you would not want to use a nonclustered index.

Another choice is a nonclustered index on `price, title`. The query can perform a matching index scan, using the index to find the first page with a price of \$20, and then scanning forward on the leaf level until it finds a price of more than \$30. This index requires about 35,700 leaf pages, so to scan the matching leaf pages requires reading about 19 percent of the pages of this index, or about 6,800 reads.

For this query, the covering nonclustered index on `price, title` is best.

## 8.6.2 Add a Point Query with Different Indexing Requirements

Strategy considerations for different indexing requirements.

The index choice for the range query on `price` produced a clear performance choice when all possibly useful indexes were considered. Now, assume this query also needs to run against `titles`:

```
select price
from titles
where title = "Looking at Leeks"
```

You know that there are very few duplicate titles, so this query returns only one or two rows.

Considering both this query and the previous query, this table shows four possible indexing strategies and estimate costs of using each index. The estimates for the numbers of index and data pages were generated using a fillfactor of 75 percent with `sp_estspace`:

```
sp_estspace titles, 1000000, 75
```

The values were rounded for easier comparison.

	Possible Index Choice	Index Pages	Range Query on <code>price</code>	Point Query on <code>title</code>
1	Nonclustered on <code>title</code> Clustered on <code>price</code>	36,800 650	Clustered index, about 26,600 pages (135,000 *.19)  With 16K I/O: 3,125 I/Os	Nonclustered index, 6 I/Os
2	Clustered on <code>title</code> Non-clustered on <code>price</code>	3,770 6,076	Table scan, 135,000 pages  With 16K I/O: 17,500 I/Os	Clustered index, 6 I/Os
3	Nonclustered on <code>title</code> , <code>price</code>	36,835	Nonmatching index scan, about 35,700 pages  With 16K I/O: 4,500 I/Os	Nonclustered index, 5 I/Os
4	Nonclustered on <code>price</code> , <code>title</code>	36,835	Matching index scan, about 6,800 pages (35,700 *.19)  With 16K I/O: 850 I/Os	Nonmatching index scan, about 35,700 pages  With 16K I/O: 4,500 I/Os

Examining the figures in this table shows that:

- For the range query on `price`, choice 4 is best; choices 1 and 3 are acceptable with 16K I/O.
- For the point query on `titles`, indexing choices 1, 2, and 3 are excellent.

The best indexing strategy for a combination of these two queries is to use two indexes:

- Choice 4, for range queries on `price`.
- Choice 2, for point queries on `title`, since the clustered index requires very little space.

You may need additional information to help you determine which indexing strategy to use to support multiple queries. Typical considerations are:

- What is the frequency of each query? How many times per day or per hour is the query run?
- What are the response time requirements? Is one of them especially time critical?
- What are the response time requirements for updates? Does creating more than one index slow updates?
- Is the range of values typical? Is a wider or narrower range of prices, such as \$20 to \$50, often used? How do different ranges affect index choice?
- Is there a large data cache? Are these queries critical enough to provide a 35,000-page cache for the nonclustered composite indexes in index choice 3 or 4? Binding this index to its own cache would provide very fast performance.
- What other queries and what other search arguments are used? Is this table frequently joined with other tables?

## 8.7 Index and Statistics Maintenance

Maintenance considerations to ensure that indexes evolve with your system.

- Monitor queries to determine if indexes are still appropriate for your applications. Periodically, check the query plans, as described in “Using showplan,” in *Performance and Tuning Series: Query Processing and Abstract Plans* and the I/O statistics for your most frequent user queries. Pay special attention to noncovering indexes that support range queries. They are most likely to switch to table scans if the data distribution changes
- Drop and rebuild indexes that hurt performance.
- Keep index statistics up to date.
- Use space management properties to reduce page splits and to reduce the frequency of maintenance operations.

### 8.7.1 Drop Indexes That Hurt Performance

Drop indexes that hurt performance. If an application performs data modifications during the day and generates reports at night, you may want to drop some indexes in the morning and re-create them at night.

Many system designers create numerous indexes that are rarely, if ever, actually used by the query optimizer. Make sure that you base indexes on the current transactions and processes that are being run, not on the original database design.

Check query plans to determine whether your indexes are being used.

See “Maintaining index and column statistics” and “Rebuilding indexes” in “Maintenance Activities and Performance,” in *Performance and Tuning Series: Physical Database Tuning*.

### 8.7.2 Choose Space Management Properties for Indexes

Space management properties can help reduce the frequency of index maintenance. In particular, choosing the fillfactor value can reduce the number of page splits on leaf pages of nonclustered indexes and on the data pages of allpages-locked tables with clustered indexes.

See “Setting Space Management Properties,” in *Performance and Tuning Series: Physical Database Tuning*.

## 8.8 Additional Indexing Tips

Performance improvement suggestions for when you are creating and using indexes.

- Modify the logical design to make use of an artificial column and a lookup table for tables that require a large index entry.

- Reduce the size of an index entry for a frequently used index.
- Drop indexes during periods when frequent updates occur, and rebuild them before periods when frequent selects occur.
- If you perform frequent index maintenance, configure your server to speed up the sorting. See “Configuring SAP ASE to speed sorting” in “Maintenance Activities and Performance,” in *Performance and Tuning Series: Physical Database Tuning* for information about configuration parameters that enable faster sorting.

## 8.8.1 Create Artificial Columns

When indexes, especially composite indexes, become too large, it may be beneficial to create an artificial column that is assigned to a row, with a secondary lookup table that is used to translate between the internal ID and the original columns.

This may increase response time for certain queries, but the overall performance gain due to a more compact index and shorter data rows is usually worth the effort.

## 8.8.2 Keep Index Entries Short and Avoid Overhead

Avoid storing purely numeric IDs as character data.

Use integer or numeric IDs whenever possible to:

- Save storage space on the data pages
- Make index entries more compact
- Improve performance, since internal comparisons are faster

Index entries on `varchar` columns require more overhead than entries on `char` columns. For short index keys, especially those with little variation in length in the column data, use `char` for more compact index entries.

## 8.8.3 Drop and Rebuild Indexes

You might drop nonclustered indexes prior to a major set of inserts, and then rebuild them afterwards. This speeds the inserts and bulk copies, since the nonclustered indexes do not have to be updated with every insert.

See “Rebuilding indexes” in “Database Maintenance” in *Performance and Tuning Series: Physical Database Tuning*.

## 8.8.4 Configure Enough Sort Buffers

The sort buffers decide how many pages of data you can sort in each run. The number of pages is the basis for the logarithmic function used to calculate the number of runs needed to finish the sort.

For example, if you have 500 buffers, then the number of runs is calculated with “log (number of pages in table) with 500 as the log base.”

Also, the number of sort buffers is shared by threads in the parallel sort; if you do not have enough sort buffers, the parallel sort may not work as fast as it should.

## 8.8.5 Create the Clustered Index First

Do not create nonclustered indexes, then clustered indexes. When you create the clustered index, all previous nonclustered indexes are rebuilt.

## 8.8.6 Configure Large Buffer Pools

To set up for larger I/Os, configure large buffers pools in a named cache and bind the cache to the table.

## 8.9 Asynchronous Log Service

Asynchronous log service, or ALS, enables great scalability in SAP ASE, providing higher throughput in logging subsystems for high-end symmetric multiprocessor systems.

You cannot use ALS if you have fewer than four engines. If you try to enable ALS with fewer than four online engines, an error message appears.

You can enable, disable, or configure ALS using `sp_dboption`:

```
sp_dboption <db Name>, "async log service", ["true" | "false"]
```

After issuing `sp_dboption`, you must issue a `checkpoint` in the database for which you are setting the ALS option:

```
sp_dboption "mydb", "async log service", "true"  
use mydb
```

```
checkpoint
```

You can use the `checkpoint` to identify one or more databases, or use an `all` clause.

```
checkpoint [all | [dbname[, dbname[, dbname.....]]]
```



## Disabling ALS

Before you disable ALS, make sure there are no active users in the database. If there are, you receive an error message when you issue the checkpoint:

```
sp_dboption "mydb", "async log service", "false"  
use mydb
```

```
checkpoint  
-----  
Error 3647: Cannot put database in single-user mode. Wait until all users have  
logged out  
of the database and issue a CHECKPOINT to disable "async log service".
```

If there are no active users in the database, this example disables ALS:

```
sp_dboption "mydb", "async log service", "false"  
use mydb
```

```
checkpoint  
-----
```

## Displaying ALS

You can see whether ALS is enabled in a specified database using:

```
sp_helpdb "mydb"  
-----  
mydb 3.0 MB sa 2  
July 09, 2002  
select into/bulkcopy/pllsort, trunc log on chkpt,
```

```
async log service
```

### 8.9.1 Understanding the User Log Cache (ULC) Architecture

The SAP ASE logging architecture features the user log cache, or ULC, by which each task owns its own log cache. No other task can write to this cache, and the task continues writing to the user log cache whenever a transaction generates a log record.

#### Context

When the transaction commits or aborts, or the user log cache is full, the user log cache is flushed to the common log cache, shared by all the current tasks, which is then written to the disk.

Flushing the ULC is the first part of a commit or abort operation. It requires the following steps, each of which can cause delay or increase contention:

## Procedure

1. Obtain a lock on the last log page.
2. Allocate new log pages if necessary.
3. Copy the log records from the ULC to the log cache.

The processes in steps 2 and 3 require you to hold a lock on the last log page, which prevents any other tasks from writing to the log cache or performing commit or abort operations.

4. Flush the log cache to disk.

Step 4 requires repeated scanning of the log cache to issue `write` commands on dirty buffers.

Repeated scanning can cause contention on the buffer cache spinlock to which the log is bound. Under a large transaction load, contention on this spinlock can be significant.

## 8.9.2 When to Use ALS

You can enable ALS on any specified database that has at least one specific performance issue, so long as your systems runs 4 or more online engines.

The specified database must have at least one of the following performance issues:

- Heavy contention on the last log page.  
You can tell that the last log page is under contention when the `sp_sysmon` output in the Task Management Report section shows a significantly high value. For example:

Task Management				
Report	Per Sec	Per Xact	Count	% of Total
Log Semaphore Con- tention	58.0	0.3	34801	73.1

- Heavy contention on the cache manager spinlock for the log cache.  
You can tell that the cache manager spinlock is under contention when the `sp_sysmon` output in the Data Cache Management Report section for the database transaction log cache shows a high value in the Spinlock Contention section. For example:

Cache c_log	Per Sec	Per Xact	Count	% of Total
Spinlock Contention	n/a	n/a	n/a	40.0%

- Under utilized bandwidth in the log device.

### i Note

Use ALS only when you identify a single database with high transaction requirements, since setting ALS for multiple databases may cause unexpected variations in throughput and response times. If you want to configure ALS on multiple databases, first check that your throughput and response times are satisfactory.

## 8.9.3 ALS Usage

Two threads—the ULC flusher and the log writer—scan the dirty buffers (buffers full of data not yet written to the disk), copy the data, and write it to the log.

### 8.9.3.1 ULC Flusher

The ULC flusher is a system task thread that is dedicated to flushing the user log cache of a task into the general log cache.

When a task is ready to commit, the user enters a commit request into the flusher queue. Each entry has a handle, by which the ULC flusher can access the ULC of the task that queued the request. The ULC flusher task continuously monitors the flusher queue, removing requests from the queue and servicing them by flushing ULC pages into the log cache.

### 8.9.3.2 Log Writer

The log writer patrols the dirty buffer chain in the log cache, issuing a `write` command if it finds dirty buffers, and monitors the wakeup queue for tasks whose pages are all written to disk.

This occurs once the ULC flusher has finished flushing the ULC pages into the log cache. It then queues the task request into a wakeup queue. Since the log writer patrols the dirty buffer chain, it knows when a buffer is ready to write to disk.

### 8.9.3.3 Stored Procedure Support for ALS

`sp_dboption` and `sp_help` support asynchronous log service.

- `sp_dboption` adds an option that enables and disables ALS.
- `sp_helpdb` adds a column to display ALS.



For more information on `sp_helpdb` and `sp_dboption`, see the *Reference Manual: Procedures*.

# Important Disclaimers and Legal Information

## Hyperlinks

Some links are classified by an icon and/or a mouseover text. These links provide additional information.

About the icons:

- Links with the icon : You are entering a Web site that is not hosted by SAP. By using such links, you agree (unless expressly stated otherwise in your agreements with SAP) to this:
  - The content of the linked-to site is not SAP documentation. You may not infer any product claims against SAP based on this information.
  - SAP does not agree or disagree with the content on the linked-to site, nor does SAP warrant the availability and correctness. SAP shall not be liable for any damages caused by the use of such content unless damages have been caused by SAP's gross negligence or willful misconduct.
- Links with the icon : You are leaving the documentation for that particular SAP product or service and are entering a SAP-hosted Web site. By using such links, you agree that (unless expressly stated otherwise in your agreements with SAP) you may not infer any product claims against SAP based on this information.

## Beta and Other Experimental Features

Experimental features are not part of the officially delivered scope that SAP guarantees for future releases. This means that experimental features may be changed by SAP at any time for any reason without notice. Experimental features are not for productive use. You may not demonstrate, test, examine, evaluate or otherwise use the experimental features in a live operating environment or with data that has not been sufficiently backed up.

The purpose of experimental features is to get feedback early on, allowing customers and partners to influence the future product accordingly. By providing your feedback (e.g. in the SAP Community), you accept that intellectual property rights of the contributions or derivative works shall remain the exclusive property of SAP.

## Example Code

Any software coding and/or code snippets are examples. They are not for productive use. The example code is only intended to better explain and visualize the syntax and phrasing rules. SAP does not warrant the correctness and completeness of the example code. SAP shall not be liable for errors or damages caused by the use of example code unless damages have been caused by SAP's gross negligence or willful misconduct.

## Gender-Related Language

We try not to use gender-specific word forms and formulations. As appropriate for context and readability, SAP may use masculine word forms to refer to all genders.



© 2019 SAP SE or an SAP affiliate company. All rights reserved.

No part of this publication may be reproduced or transmitted in any form or for any purpose without the express permission of SAP SE or an SAP affiliate company. The information contained herein may be changed without prior notice.

Some software products marketed by SAP SE and its distributors contain proprietary software components of other software vendors. National product specifications may vary.

These materials are provided by SAP SE or an SAP affiliate company for informational purposes only, without representation or warranty of any kind, and SAP or its affiliated companies shall not be liable for errors or omissions with respect to the materials. The only warranties for SAP or SAP affiliate company products and services are those that are set forth in the express warranty statements accompanying such products and services, if any. Nothing herein should be construed as constituting an additional warranty.

SAP and other SAP products and services mentioned herein as well as their respective logos are trademarks or registered trademarks of SAP SE (or an SAP affiliate company) in Germany and other countries. All other product and service names mentioned are the trademarks of their respective companies.

Please see <https://www.sap.com/about/legal/trademark.html> for additional trademark information and notices.